



**CMT**  
*monitoring innovation*



# Condition Monitoring Product Catalogue

# Introduction

## World Class Innovations in Condition Monitoring

CMT is a specialised manufacturer for on-line and on-site condition monitoring solutions. Our equipment enables onsite engineers to make on the spot informed decision helping with the daily maintenance job. The inhouse developed and manufactured products are trusted by customers all over the world especially.

CM Technologies, formerly known as Kittiwake GmbH, helps to prevent unplanned breakdown, minimise wear and tear and maximise plant availability. There are various different on-the-run tools available for condition monitoring:

- Condition monitoring of operating fluids (lubricants, fuel, water / on-site or in a lab)
- Vibration Analysis, Acoustic Emission or Sound for fault identification
- Monitoring physical properties (speed, rpm, temperature, pressure, power ....) to maximise efficiency

Offering rugged onsite equipment as well as online technologies covers most usages for all kinds of situations.

Whereas both variants do not provide the same results, each provide their individual benefits.

The best solution is often a combination of two or three of the condition monitoring tools, but it depends very much on the type of your condition monitoring equipment you have in use, the criticality of that equipment, the running conditions (speed, rpm, temperature ...) of your equipment, and how perceptive your organization is to training.

CMT can offer you a complete solution as an on- and offline system tailor-made to your specifications. With individual training, your staff will manage each challenge on the high seas. We are pleased to help you find the right solution.



We would like to give this catalogue to interested parties and to customers who would like to acquire more knowledge about available solutions or update their already kept information.

In case of any remaining questions, our sales team is always keen to answer all questions. Making informed purchases is important to future-proof the health of all machinery.

The CMT-Team

## Quality assured manufacturing with a focus on continuous improvement



Ever since CM Technologies GmbH was founded, its paramount objective has been to manufacture and sell only high-quality products that reflect the state-of-the-art technology and meet customer requirements, with the aid of motivated employees. This self-imposed quality obligation and our experience in condition monitoring technology have enabled us to succeed in achieving a prominent market position. In line with the aspiration to continue to guarantee the highest degree of quality to our customers in the future and not only to cement the reputation of our company and related market position, but to enhance it further, we introduced a quality management system in accordance with DIN EN ISO 9001 across our entire company. In addition, we would like to fulfil our customers' requirements by maintaining a very close partnership with them, demonstrating that customers can rely on us and that we deserve their trust.

## Environmental protection and sustainable development

Both are priority objectives of CM Technologies GmbH corporate policy. Already from the beginning, the shareholders have adopted guidelines to the environmental care. To achieve this, we have implemented an Integrated Environmental Management System that meets the requirements of ISO 14001. This policy is periodically reviewed and is monitored by measurable objectives, as part of a continual improvement process. All staff are briefed on this policy and made aware of the objectives. The policy is displayed on the company website, to demonstrate our commitment to the environment.

## Oil Condition Monitoring

1. Onsite Oil Test & Solutions .....	4
2. Cylinder Drain Oil Management .....	20
3. Independent Laboratory Oil Test .....	28
4. Online Oil Sensors.....	30
5. Sampling Solutions .....	35

## Water Condition Monitoring

1. Marine Potable Water Test Kit.....	44
2. Marine Sewage Water Test Kits.....	49
3. Ballast Water Test Kit .....	50
4. Cooling and Boiler Water Test Kits .....	52
5. Marine Automatic Fire Sprinkler System .....	53
6. Produced Foam.....	54
7. Scrubber Caustic Test Kit.....	54
8. Cutting Fluid Test Kit.....	54

## Vibration Monitoring

1. Vibration Meter .....	56
2. Vibration Analyser.....	61
3. Vibration Monitor .....	67
4. Software.....	70
5. Spares and Accessories .....	72

## Performance and Efficiency Monitoring

1. Mechanical Peak Pressure Indicator.....	76
2. PREMETS M.....	77
3. PREMETS X.....	78
4. PREMETS Software .....	80
5. PREMETS Online 24/7 .....	84
6. Pressure and Temperature Calibration .....	85

## Service and Training

1. Evaluation Service .....	89
2. Installation and Commission Service.....	90
3. Calibration Service .....	92
4. Oil Testing Seminar .....	94
5. Monitoring with Vibration Analysis Seminar .....	95
6. Diesel Performance Seminar.....	96
7. Cylinder Drain Oil Management Seminar .....	97
8. Marine Water Tests Seminar.....	98



# Oil Condition Monitoring

1. Onsite Oil Test & Solutions .....	4
2. Cylinder Drain Oil Management .....	20
3. Independent Laboratory Oil Test .....	28
4. Online Oil Sensors.....	30
5. Sampling Solutions .....	35

## 1. Onsite Oil Test & Solutions

CMT's oil test kit range provides on-site test equipment invaluable for any engineers responsible for high value lubricated machinery or hydraulic equipment. Economically priced these condition monitoring tools quickly will become the backbone of your maintenance regime.

Engineers and maintenance managers are given the ability to conduct oil analysis directly on-site at the running machine. Spot out-of-spec fuels and lubricants before they become a critical problem by using our kits. You can choose from a wide range of different options including complete test cabinets ensuring you get the right tool for your machinery.



Engine Oil Test Kit

Some of our test devices need chemicals for the test routines. CMT continually invests in new developments to reduce the number of chemicals needed.

As a result of this we are currently in the position to supply most of our test kits without reagents which are hazardous for shipping. All our water in oil test devices use non-hazardous reagents. At the same time they still work with any old style reagents offered on the market. On the other hands our reagents can be used in any other test device available on the market. With this backward compatibility the user enjoys a great deal of flexibility when it comes to buying refill reagents or any new or replacement test device.

On-site oil analysis equipment provides your chance to monitor the condition of your oil between laboratory checks. Based on our experience in oil condition monitoring our kits are made to be used by anyone because no training or special knowledge is needed. Important oil parameters can be measured in a few minutes. Step by step instructions and on screen user guides make using the kits as simple as ever.

CMT Onsite Oil Test Solutions are available as single Parameter Test Kit or as a multiparameter.

### Your benefits:

- Fast and accurate results.
- Regular use of CMT's oil condition monitoring equipment helps avoid expensive machinery failures
- Allow you to make informed on-site maintenance decisions.
- Accurate results are available on-board or in the field immediately without any time delay.
- Allow you to act before critical failure arise.
- Robust and reliable for use in harsh environments.
- Save time and money by knowing exactly when to change the oil.

## Multi Parameter Combinations

**CMT test kits are supplied either in durable aluminium cases or in wall mounted steel cabinets. Our Multi Parameter Test Kits contain all of the necessary equipment and consumables for your oil condition monitoring needs.**

With CMT you have the choice to order a single device or you choose one of CMT's Multi Parameter Combinations. Those combinations give you the advantage of having all the needed tests for certain situations in one place. As listed on the next two pages the combinations, they are being delivered in either a high quality aluminium case or a steel cabinets.

The aluminium case has the advantage of mobility. Take the Test Kit where ever you need it.

The cabinets offer a lot more space and can be mounted to a wall. Misplacing and searching will be a thing of the past.

## Multi- Parameter Combinations - Test Kits

### Digital / Manual Test Kits

Product name	Part number	Combination						
		Viscotube	Water in Oil Cell	Combined Water in Oil/BN Cell	Salt Test	Insoluble	AN Test	Viscostick
WaVis Oil Test Kit	OTC-CT-20001		<input checked="" type="checkbox"/>					<input checked="" type="checkbox"/>
Basic Oil Test Kit	OTC-CT-20002		<input checked="" type="checkbox"/>		<input checked="" type="checkbox"/>	<input checked="" type="checkbox"/>		<input checked="" type="checkbox"/>
Engine Oil Test Kit	OTC-CT-20003			<input checked="" type="checkbox"/>		<input checked="" type="checkbox"/>		<input checked="" type="checkbox"/>
Field Oil Test Kit	OTC-CT-20004			<input checked="" type="checkbox"/>		<input checked="" type="checkbox"/>	<input checked="" type="checkbox"/>	<input checked="" type="checkbox"/>
Engine Oil Test Kit II	OTC-CT-20005	<input checked="" type="checkbox"/>		<input checked="" type="checkbox"/>		<input checked="" type="checkbox"/>		<input checked="" type="checkbox"/>
Marine Oil Test Kit	OTC-CT-20006			<input checked="" type="checkbox"/>	<input checked="" type="checkbox"/>	<input checked="" type="checkbox"/>		<input checked="" type="checkbox"/>
Hydraulic Oil Test Kit	OTC-CT-20007	<input checked="" type="checkbox"/>	<input checked="" type="checkbox"/>				<input checked="" type="checkbox"/>	

		Water in Oil Cell	Density Hydrometer	Low Range Falling Ball Viscometer	Free Fatty Acid Test/ AN Test	Visual Test (Cleanliness)
Diesel Oil Test Kit	OTC-CT-20008	<input checked="" type="checkbox"/>	<input checked="" type="checkbox"/>	<input checked="" type="checkbox"/>	<input checked="" type="checkbox"/>	<input checked="" type="checkbox"/>



Electronic Cylinder Drain Oil Test Kit



Oil Test Kit

## Multi Parameter Combinations - Cabinets

### Fuel and Lube Test Cabinet Configurations

	Part Number	Electronic Water & BN Cell	Heated Viscosity Meter	Density Meter	Dispersency Spot Test	Electronic Insolubles Test	Compatibility Meter	Salt Test	Pour Point	Electronic AN Test	Cat Fines
Marine Fuel & Lube Test Cabinet	OTC-CT-30010	<input checked="" type="checkbox"/>	<input checked="" type="checkbox"/>	<input checked="" type="checkbox"/>	<input checked="" type="checkbox"/>			<input checked="" type="checkbox"/>	<input checked="" type="checkbox"/>	(Option)	
Diesel Engine Power Plant Cabinet	OTC-CT-30011	<input checked="" type="checkbox"/>	<input checked="" type="checkbox"/>	<input checked="" type="checkbox"/>	<input checked="" type="checkbox"/>	<input checked="" type="checkbox"/>	<input checked="" type="checkbox"/>	<input checked="" type="checkbox"/>	<input checked="" type="checkbox"/>	(Option)	
Gas Engine Power Plant Cabinet	OTC-CT-30012	<input checked="" type="checkbox"/>	<input checked="" type="checkbox"/>		<input checked="" type="checkbox"/>	<input checked="" type="checkbox"/>				<input checked="" type="checkbox"/>	
Heavy Fuel Oil Cabinet	OTC-CT-30014	<input checked="" type="checkbox"/>	<input checked="" type="checkbox"/>	<input checked="" type="checkbox"/>			<input checked="" type="checkbox"/>				<input checked="" type="checkbox"/>

All cabinets can be ordered with an optional Flash Point Tester.

	Part Number	Electronic CDO BN Cell	Electronic Iron Console	Electronic Insoluble	Electronic Water Test
CDO Analysis Kit	OTK-CT-11220	<input checked="" type="checkbox"/>	<input checked="" type="checkbox"/>	(Option)	(Option)



Oil Analysis Cabinet

## Ferrous Wear Debris Meter

Testing lubricant samples for ferrous wear debris is an established method to detect developing and impending damages as well as gaining knowledge about the wear life cycle of the tested equipment. CMT's newest development - the Ferrous Wear Debris Meter - is an accurate, easy-to-use solution for offline and at-line measurements of ferrous wear debris concentrations.

Gain the insight necessary to determine the condition of your equipment. Applicable for diverse applications like Cylinder Drain Oil of 2-stroke diesel engines gearboxes or other machinery.



The **Ferrous Wear Debris Meter** provides repeatable and accurate determination of ferromagnetic material concentration down to single ppm levels.

It provides a mass proportional output from any size or quantity of ferrous contaminant particles, even sub-micron particles. Particle size does not affect the measurement (in contrast to spectrometric methods). Readings are unaffected by properties (dielectric) of fluid base, or additive package, or water content. Readings are straightforward and are presented in ppm.



### Ordering Information

OTK-CT-20500

#### FWDM Ferrous Wear Debris Meter

Range:	0 - 2000 ppm
Resolution (ferrous):	down to 1 ppm
Repeatability:	+/- 10 ppm typically
Power supply:	12 V DC @ 250 mA
Weight (device):	485 g
Test time:	1 second

OTS-CT-13039

#### FWDM Consumables Pack

No. of 2 ml Test tubes: 250

## FPQ Ferrous Debris Monitor

Rapid screening of oil samples for ferrous wear debris using a PQ Index instrument has become an established method in most used oil laboratories. It is a brilliant wear indication and provides even further information if seen in relation to other elementary analysis methods.

There are several sources for iron wear particles in lubricants or grease such as scratched surfaces, erosion or broken parts. Often the particles are larger than 5 microns which is a size which will not be detected by laboratory methods like ICP (Inductively Coupled Plasma).



The instrument's standard USB connection can be used to transfer data directly into an existing LIMS system.

The FPQ has been designed to work with standard 100 ml sample bottles. This allows to take the measurement without having to transfer the sample to another specialized container. The device can also be used with standard 2 ml grease pots. Adapters for different sample vessels are available on request.

A high PQ index often indicates a serious wear problem which causes large particles to appear in the sample. The device measures all ferrous particles in a sample regardless of the size. Its innovative sensor and data processing guarantee a good stability and high sensitivity.



### Ordering Information

OTK-CT-11224

#### FPQ Ferrous Debris Monitor

Range:	0 - 15000 PQ
Repeatability:	+/- 5 PQ for < 500 PQ 1% for results > 500 PQ
Power supply:	230 V DC (50/60 Hz)
Test time:	10 seconds
Dimensions:	430 x 380 x 155 mm
Weight:	7.5 kg

SAM-CT-70288

#### 100 ml Sample Bottles, (288)

Neck:	38 mm
Material:	PETG

SAM-CT-70289

#### 100 ml Sample Bottles, (288)

Neck:	38 mm
Material:	HDPE



## IR Analyser (ATR)



**With the newly developed CMT IR Analyser, based on attenuated total reflection, a new chapter of IR spectroscopy is opened in the middle infrared spectral range. Due to the no-moving-parts design, applications even in harsh environmental conditions are made possible. The small size and low power consumption clearly stands out from conventional IR spectrometers available on the market.**

IR spectroscopy is a powerful technique for measuring the concentration of organic molecules. The physical effect of infrared light absorption by molecules contained in the sample is being measured. Each molecule absorbs light of a certain wavelength. The intensity of the absorption is a measure of the concentration of the particular molecule.

During the life cycle of an oil, different decomposition and conversion processes occur at the molecular level. A drop of oil acts as an information memory for both equipment and oil condition, which can be decrypted by IR spectroscopy.

### Three interacting mechanisms together form the process of oil aging:

- Base oil degradation,
- Additive depletion and
- Contamination

Base oil degradation predominantly is driven by oxidation processes caused by oxygen and heat. Typical oil condition parameters are: Oxidation, AN, BN, nitration, sulphation, ...

Commonly used additives are e.g. antifoaming additives, anti-wear additives and antioxidants. During oil aging the concentration of additives decreases and degradation products emerge. This oil aging mechanism is being indicated by the concentration of molecules with central ions of zinc, molybdenum, phosphorus, calcium, magnesium, barium or sodium.

Oil contamination is often caused by foreign substances such as water, glycol, diesel, petrol or other oils.

The oil condition sensor of the **IR Analyser** detects the three major oil degradation mechanism simultaneously. The standard oil condition parameters, that are commonly obtained by laboratory based analysis, are being calculated from the measured IR spectra.

The sensor is based on a spectral apparatus that is being constructed with no moving parts, which makes it durable and virtually maintenance free. Meaningful oil condition parameters are calculated from the recorded spectra by a previously built oil-specific calibration (chemometric model).

In addition to portable systems for rapid on-site analysis, device models for use in the laboratory are available – as well as rugged field installations for inline operation.



### Ordering Information

OTK-CT-11215

#### Electronic IR Analyser

Infrared Analyser based on ATR

Including software displaying:

- Water Content
- Soot Content
- Antioxidant Depletion
- Glycol Contamination
- Sulphate
- Oxidation
- Nitration
- Phosphate.

### Specification IR Analyser

Spectral Range	2.5 - 5.0 $\mu\text{m}$ (4000 - 2000 $\text{cm}^{-1}$ ) or 5.5 - 11.0 $\mu\text{m}$ (1818 - 909 $\text{cm}^{-1}$ )
Communication	Ethernet / USB / Bluetooth
Protection	IP 64
ATR Crystal	ZeSe
Number of Reflections	9
Display	External software on PC (not supplied)
Power	Battery pack LiPo - 5 V DC, 4 Watt
Housing Material	Aluminium, anodized
Dimensions	170 x 76 x 40 mm
Weight	730 g

## Water in Oil



CMT Water TouchCell

**Water is the biggest threat any oil lubricated system faces. Depending on the application water can cause serious problems for the equipment or safety. Maintain and protect your equipment by monitoring the water content.**

Most parameters can be trended well by offline laboratory oil tests. This is not the case when it comes to water ingress. Water is not a by-product of the aging of oil or a result of the usage of the oil. Water ingress can come quickly and without any prior warning. Once established water levels may rise very fast. Therefore a trend analysis in a shore based laboratory does not allow a close enough monitoring of the water content to avoid problems due to a sudden water ingress.

### Your benefits:

- All parts (sensor, display, battery pack etc.) can be exchanged when needed
- Now 30% bigger backlit display for better visibility
- Solid rugged metal housing for higher durability
- Multiple ranges for exact readings
- Multilingual software
- No hazardous reagents needed
- Undercut in the bottom to assist dosing the chemicals for all tests



WIO Reagents

### Ordering Information

OTK-CT-11201

#### Electronic Water in Oil Test Kit

Range: 0 - 1500 ppm,  
(lowest reading 100 ppm)  
0 - 6000 ppm,  
(lowest reading 200 ppm)  
0 - 1 %,  
0 - 5 %  
Accuracy: +/- 0.01 % free water  
Weight: 490 g  
Test Time: 5 minutes  
Reagents: non hazardous  
Memory: last 10 readings for each individual oil

OTS-CT-13001

#### Water TouchCell

OTS-CT-13004

#### Set of O-Rings for TouchCell

SW-C00004-CT

#### Download Option TouchCell

License for data download

The newly developed **Electronic Water in Oil TouchCell** does provide highest accuracy on site when testing Water in Oil giving results after a few minutes.

- Prevent corrosion, cavitation or failure of your machinery by detecting water in oil, before any damage occurs.
- Minimize instability of additive packages and damaging microbe growth by monitoring your oil.

## Combined TouchCell



**CMT is offering a Combined TouchCell which offers both Water in Oil and BN testing in one device.**

With the **Combined TouchCell** you only need one device to measure two important parameters. You can switch freely between the two modes in the software and of course you will have the same accuracy as with the individual TouchCell. With the Combined TouchCell you have an economic but powerful onsite measuring tool in your hand.

### Ordering Information

OTS-CT-13003

#### Combined TouchCell (Water + BN)

Specs: Please see the Water in Oil and Base Number sections

OTS-CT-13004

#### Set of O-Rings for TouchCell

SW-C00004-CT

#### Download Option TouchCell

License for Datadownload

# Base Number (BN)



CMT Electronic BN TouchCell



BN Reagent



Electronic BN TouchCell

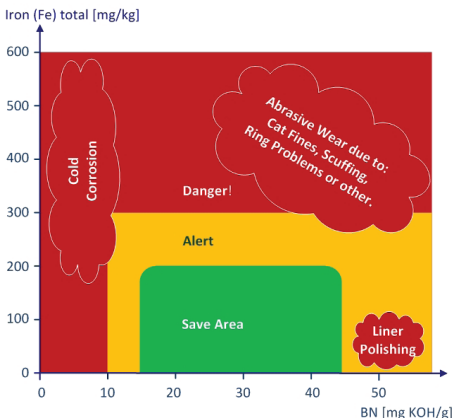

Measure the alkaline reserve in engine oils is important to maintain the ability of the lubricant to neutralize acids resulting from combustion.

To avoid acid corrosion inside a combustion engine it is essential to maintain a certain alkalinity reserve. Additives (mostly calcium) are added to the oil to neutralize any acid which might build up during the combustion process.

Normally the BN of an engine lube oil decreases with the running hours. In two stroke engines the circulation oil gets contaminated with leaking cylinder oil which has a much higher BN. This leads to a steep increase of the BN value of the engine system oil.

The CMT BN Test Kit provides state of the art analysis and gives fast, accurate results within a couple of minutes.

The **Standard BN Test Kit** has been developed for all standard applications like testing the system oil used in all kinds of diesel engines and the **CDO BN Test Kit** has been specially developed to test the scraped down cylinder drain oil in two stroke crosshead engines.

The CDO BN Test Kit software has been developed specifically to give reliable results despite the fact that used drain oil may have dropped down to only 10% BN reserve left compared to the fresh oil.

The CMT **BoB BN Test Kit** allows to test the base number of cylinder oils blended on board. It will report the BN of the blend as well as the mixing ratio. Furthermore, the BOB BN Cell allows to test the remaining BN of the drain oil and the remaining BN of the system oil. For easier handling it allows to store calibration for 5 different system oils and 3 different cylinder oils for drain oil testing.

Following Test Kits are available:

**Standard BN** - for system oil only

**CDO BN** - for cylinder drain oil only

**BoB BN** - for system oil, cylinder drain oil and blending

## Ordering Information

OTK-CT-11202

**Standard BN Test Kit** (for system oil)

Range: 1-180 BN  
 Accuracy: Typically +/- 5 % of fresh oil BN  
 Dimensions: Ø 68 mm x 84 mm  
 Weight: 490 g  
 Test Time: 5 minutes  
 Memory: last 10 readings for each individual oil  
 Reagents: non hazardous

OTK-CT-11214

**CDO BN Test Kit** (for cylinder drain oil)

Range: 1-180 BN  
 Accuracy: Typically +/- 5 % of fresh oil BN  
 Dimensions: Ø 68 mm x 84 mm  
 Weight: 490 g  
 Test Time: 5 minutes  
 Memory: last 10 readings for each individual oil  
 Reagents: non hazardous

OTK-CT-11217

**BoB BN Test Kit**  
 (for blending, cylinder drain oil)

Range: 1-500 BN  
 Accuracy: Typically +/- 2% or +/- 3 of fresh oil BN  
 Dimensions: Ø 68 mm x 84 mm  
 Weight: 490 g  
 Test Time: 5 minutes  
 Memory: last 10 readings for each individual oil  
 Reagents: non hazardous

## Reagent & Spares

OTS-CT-13002:

**Spare BN TouchCell**

OTS-CT-13027:

**Spare CDO BN TouchCell**

OTS-CT-13006:

**Spare BOB BN TouchCell**

OTS-CT-13004

**Set of O-Rings for TouchCell**

SW-C00004-CT

**Download Option TouchCell**

License for Datadownload

## Viscosity / Density Meter



Viscosity / Density Meter with hydrometer

The **Viscosity / Density Meter** can measure at 25°C, 40°C, 50°C or 60°C and displays results at 40°C, 50°C and 100°Cv. It also allows to measure very high viscosities with pin point accuracy.

The **Viscosity / Density Meter** is supplied with a hydrometer. Density is measured at 50°C and directly shown converted to 15°C, giving fast, accurate results. No calculation is needed.

As with all CMT Devices, the software is easy and intuitive to simplify the procedure as much as possible. All steps are easily explained on the screen.

**CMTs Viscosity / Density Meter combines two very important parameters for condition monitoring. The inhouse developed device will guide you through the procedure and give you fast results with a high accuracy.**

Testing the viscosity and density is important in every aspect of the marine or industrial areas.

The efficiency of every engine depends on the right viscosity of the fuel.

Viscosity is fundamental to maintaining the integrity of a lube oil film.

Lubrication is very important to prevent metallic contact, scuffing, micro welding and wear of sliding surfaces.

- Measuring the oil viscosity provides an early detection of contamination, fuel ingress and shear thinning.
- Suitable for all mineral oils or fuels down to 1.5 cSt up to 999 cSt (heated viscometer only).
- Allows to calculate the combustion performance (CCAI) of fuel or injection / storage temperature.

The right amount of fuel cannot be determined by volume or weight alone. Depending on the injection temperature these values might vary widely. Density is required for quantity calculations and also to determine the optimum size of the gravity disc for the centrifuge. Diesel / fuel oil density also gives an indication of other fuel characteristics, including specific energy and ignition quality (CCAI).

The density is used to confirm the quantity and grade of fuel delivered.

- Ensure the correct amount and grade of fuel has been delivered to your ship
- Ensure you have been supplied with fuel and not a mixture from fuel and gas (cappuccino effect)



Viscosity / Density Meter with accessories

### Ordering Information

OTK-CT-11231

#### Viscosity / Density Meter

##### Viscosity

Range: 2.6-865 cSt @ 40 °C  
2.2-683 cSt @ 50 °C

Test Time: Heating from ambient temperature ca. 5 minutes  
about 3 minutes test time

Calculation: Injection Temperature  
Storage Temperature

Reagents: N/A

##### Density

Range: 800 to 1010 kg/m<sup>3</sup>

Test Time: Heating from 15°C about 10 minutes

Repeat Test: maximum 2 minutes

Cleaning: 10 minutes

Reagents: N/A

##### Device

Display: Backlit LED  
Touch input

Power: 90W

Input DC: 24V / min 3,75A

Weight: 2 kg

Dimensions: 26 x 24 x 6 cm<sup>3</sup> (H x W x D)  
(without stand)

Interface: Micro-USB

OTR-CT-11000

#### Test Kit Cleaner (250 ml)

### Your benefits:

- Fast and accurate results.
- Combination of two tests within one device.
- Simple measurements for compelling results.
- Avoid wear by keeping track of the viscosity.
- Increase efficiency with the right volume.
- Measure Density for quantity and grade of fuel.

## Viscosity



Viscotube

The **CMT Viscostick** provides information whether the viscosity has increased or decreased. Typically it will detect 5-10% fuel dilution as well as increases in viscosity due to oil contamination like water. It can not be used to get an actual viscosity value but you will get an idea whether the viscosity is greater or smaller than the viscosity of the reference oil. It is essential that both oils have the same temperature at the time of the measurement.

The **CMT Viscotube** is a falling ball viscosimeter allowing to measure the viscosity of oil in centistokes on site.

The Viscotube closes the gap between the low cost viscosity stick and the highly accurate Heated Viscosity Meter.

The Viscotube is equipped with a clear screw cap at each end allowing to see the falling ball arrive at the other end. A tripod support stand on a mirror base plate helps to monitor the falling ball. The device is supplied with three sizes of balls to cover a wide range of viscosity. A digital thermometer is used to measure the temperature after completing the test.

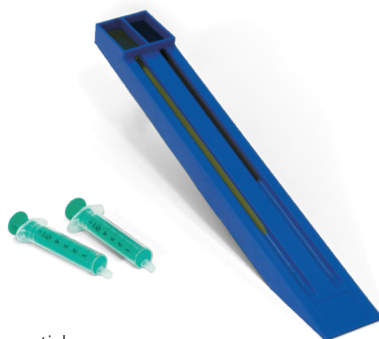

Viscostick

### Ordering Information

OTK-CT-11005

#### Viscotube Oil Test Kit

Range: 20-600 cSt @ 40°C, using three sizes of balls

No. of Tests: Unlimited

Test Time: 1 - 10 minutes

Reagents: N/A

OTK-CT-11004

#### Viscosity Oil Test Kit

Range: go / no go

Application: Lubricating oils, viscous hydraulics

No. of Tests: Unlimited

Test Time: 1 minute

Reagents: N/A

OTR-CT-11000

#### Test Kit Cleaner (250 ml)

## Compatibility Tester

**With the growing use of low sulphur fuels and increased frequency of bunkering, testing the stability of the fuel oil and its compatibility for blending is becoming increasingly important.**

Whilst every fuel oil is manufactured to be stable - in that it does not have the tendency to produce asphaltic sludge - two stable fuel oils are not necessarily compatible when blended or mixed together.

With the Sulfur Cap of 2020 more paraffinic blend components are used in VLSFO. Therefore the stabilizing effect on asphaltenes from aromatics are lost. Mixtures can become instable much faster.

The **Compatibility Tester** will quickly identify potential fuel stability problems.

It will also rapidly determine if a fuel is compatible with existing fuel stocks.

- Identify possible stability problems before mixing fuels, giving you peace of mind when accepting fuel deliveries.
- Prevent sludge deposits, failure of fuel handling systems and costly combustion related engine damage.

### Your benefits:

- Easy test procedure.
- Avoid sludge build up.
- Check fuels to comply with the Sulfur Cap 2020.
- Quick inputs via touch screen

### Ordering Information

OTK-CT-11216

#### Electronic Compatibility Tester

Range: As per ASTM D4740

Accuracy: Variation of 1 rating in 20 repeat tests

Test Time: 20 minutes (attended), 1 hour (unattended)

OTS-CT-13032

#### Spare Chromatography Paper (100)

OTS-CT-13030

#### Consumables Glass Pack (10)

OTR-CT-11000

#### Test Kit Cleaner



Compatibility Tester

**Cat Fines, primarily chemical aluminium and silicon compounds, are catalysts, which are used to optimise the cracking process in the refineries for the production of petrol and other fuels.**

Although useful for the fuel production Cat Fines are extremely abrasive and have to be removed from the oil residues after the refining process to avoid severe damages to the engines running with residual fuel oil.

**Econ Cat Fines Test Kit - economic go / no go indicator**

As a means of self-preservation, vessels collect representative fuel samples during bunkering and then send them off for laboratory analysis. However, the test results often only become available once the vessel is already sailing again, by which time the fuel might be in use already and significant engine damage may already be in progress.

The new **Econ Cat Fines Test Kit** has been specifically designed to provide the crew with a clear sail or don't sail indication with regards to fuel quality.

The **Econ Cat Fines Test** can indicate HFO samples that are contaminated with dangerous levels of cat fines even before the fuel has even been pumped aboard. The test can be completed within a few minutes, is cost effective and is simple to perform.

Laboratory results show that the new test is capable of identifying those fuel samples that have a cat fines concentration of > 60 ppm (Al + Si), and which therefore exceed the limit recommended by ISO 8217:2012.

It also allows to check roughly if the filters and separators bring out the required amount of cat fines and therefore avoiding damage to the engine.

**Electronic Cat Fines II Analyser - accurate high end device**

Although the amount of Cat Fines in the bunkered fuel is normally known from the documentation provided by the supplier, the Cat Fines content before the fuel oil separators and consequently before entering the engine is usually unknown.

Due to accumulation of Cat Fines in storage- or day tanks over time the concentration of Cat Fines before separators and consequently before the engines may deviate significantly from the demanded value, especially during rough sea passages.

To measure the actual and current Cat Fines concentration in the fuel on board with a reasonable degree of accuracy has not been possible so far.

With the new **Electronic Cat Fines II Test Kit** you are capable of determining the concentration of catalytic fines in fuel.

The affordable test is easy to perform and the device displays directly the measured values in "ppm" with high accuracy.

**Your benefits:**

- Revolutionary new system
- Allows multiple tests at different sampling points
- Low costs per test
- Only small fuel sample size needed



Electronic Cat Fines II



Econ Cat Fines



~15 ppm



~40 ppm

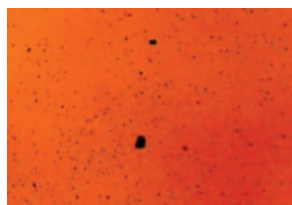

~100 ppm

**Ordering Information**

OTK-CT-11229

**Cat Fines II SM Test Kit**

Range: 8 - 70 (140) ppm  
Accuracy: +/- 5 ppm (Al)  
Test Time: 10 minutes  
No. of Tests: 30

OTR-CT-12013

**Cat Fines II Reagent Pack (30)**

OTR-CT-12010

**Vial Cleaner**

OTS-CT-13029

**Glass Vial Consumables Pack (100)**

OTK-CT-11222

**Econ Cat Fines Test Kit**

Range: 15-200 ppm  
Accuracy: +/- 5 ppm (Al)  
Test Time: 1 minute  
No. of Tests: 30

OTR-CT-12014

**Econ Cat Fines Reagent Pack (30)**

SAM-CT-70071

**500 ml Fuel Oil Sample Bottle Pack**

SW-C00002-CT

**Download Option Console**

License for data download

## XRF Onboard Sulfur Tester

The XRF Onboard Sulfur Tester is an easy-to-use and robust analyzer, designed to provide high-precision ISO 8754 and D4294 sulfur analysis for the marine industry in preparation for the IMO 2020 regulation. It is able to deliver the most practical and effective solution to meet customer's application needs.

The Sulfur Tester was developed to measure sulfur in hydrocarbons like crude oil, mineral oil, diesel, gasoline, marine fuel, jet fuel, kerosene and lubricants.

In 2015, SECA trade partners restricted sulfur emissions to 0.1% sulfur content within 24 nautical miles (or less) from shore. On January 1, 2020, the International Maritime Organization's (IMO) revised MARPOL Annex VI rule will come into effect, which will lower the maximum global sulfur cap for emissions from 3.50% to 0.50%.

While the Emission Control Areas (ECAs) will remain at the 2015 standard of 0.10% S content. To ensure compliance with both regulations, merchant ships will need to strictly monitor sulfur content in fuel. XRF Onboard Sulfur Tester was designed to meet these needs with easy, rapid, and precise sulfur analysis.

The XRF Onboard Sulfur Tester delivers fast and precise sulfur testing with a limit of detection as low as 0.0050% - well below the new regulatory limits. To ensure lab-quality results and compliance with methods approved for marine-fuel testing (covered under ISO 8217), the XRF Onboard Tester is compliant with ISO 8754 and ASTM D4294 regulations in the concentration range of 0.01%-5%.

An innovative sample carrier that is compatible with both sample bottle and sample cup opens the field of use for the compact and robust XRF Onboard Sulfur Tester making it the perfect solution for onboard use. The sample is inserted with the sample window vertical, ensuring that any accidental sample leak goes into a drip tray which could be simply removed and cleaned. If desired, the sample preparation is as easy as replacing the sample bottle cap with a Z-cap with a built-in thin film.

Thanks to its easy and intuitive software this analyzer can be operated by a crew member with minimal training, in some cases less than 15 minutes.

The robust stability has been tested through continuous measurement of standard NIST fuel oil sample 1619b (0.698%) within the temperature range from 10 °C to 30 °C.

With corrected net counts, the calibration covers the whole range of marine application with one linear curve, ensuring robust calibration with precise sulfur analysis.



### Your benefits:

- Robust design for maritime environment
- Onboard, offshore, or on-land testing
- Portable with built-in battery
- Minimum sample preparation with sample bottle
- Advanced detector to ensure long-term stability
- Trusted precision with lab-quality results
- Robust calibration with one curve covering whole range
- Complies with ASTM D4294, ISO 8754, and IP 336

### Ordering Information

OTK-CT-11227

**XRF Onboard Sulfur Tester**

		XRF Onboard Sulfur Tester	
Dynamic Range		Sulfur 50 ppm - 5 wt%	
Applications		S in hydrocarbons like crude oil, mineral oil, diesel, gasoline, marine fuel, jet fuel, kerosene, and lubricants	
Method Compliance		ASTM D4294, ISO 8754 & IP 336	
Measure time		30 - 900 seconds	
Calibration		- 30 different calibration curves - Linear (automatic custom Calibration available)	
Sample volume	cap bottle	- 7-10 ml	- 25 ml
Connections		USB, Ethernet	
Data Output		Printout, USB and Ethernet to PC	
Dimensions		23 cm x 30 cm x 26 cm	7,2 kg
AC Power Supply		110-240 VAC ± 10%, 50-60 Hz	
Battery Power		98Wh > 4 hours continuous	
Operating temp.		5 °C - 40 °C	
Operating Humidity		30 - 85%	

# HDXRF Sulfur and Multi Element Analyser

**CMTs HDXRF Analysers can measure the concentration of different elements within the oil. We offer one analyser for sulfur only and a second for multiple elements like P, Cl, K, Ca, V, Cr, Mn, Fe, Co, Ni, Cu and Zn.**

The analysers are powered by High Definition X-Ray Fluorescence (HDXRF®) technology: an elemental analysis technique offering significantly enhanced detection performance over traditional XRF technology. This technique applies state-of-the-art monochromating and focusing optics, enabling dramatically higher signal-to-background ratio compared to traditional polychromatic X-Ray fluorescence.

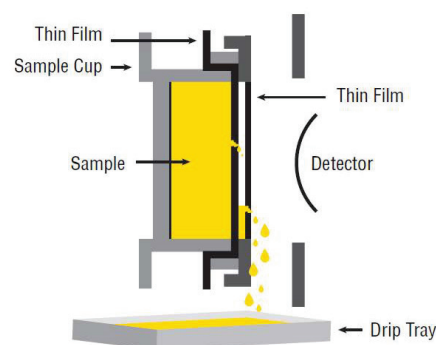

The analysers comply with ASTM D4294 and ISO 8754 for sulfur analysis of hydrocarbons like crude oil, diesel, gasoline, jet fuel, and lubricants. The Sulfur Analyser delivers precise sulfur analysis with limits of detection as low as 2.6 ppm. The Multi Element Analyser delivers sulfur measurements with a limit of detection as low as 5.7 ppm with rapid monitoring of critical elements like Ni, V, and Fe at sub-ppm levels.

### Your benefits:

- Higher signal-to-background ratio.
- Improved precision.
- lower limits of detection.
- Drip tray to prevent sample leakage.
- Lightweight, robust design
- No need for purge gas or vacuum

Petroleum laboratories depend on reliable, robust analytical solutions for their fast-paced environment. The analysers was designed to meet these needs with an innovative sample introduction system that directs accidental spills to a drip tray and away from valuable components.

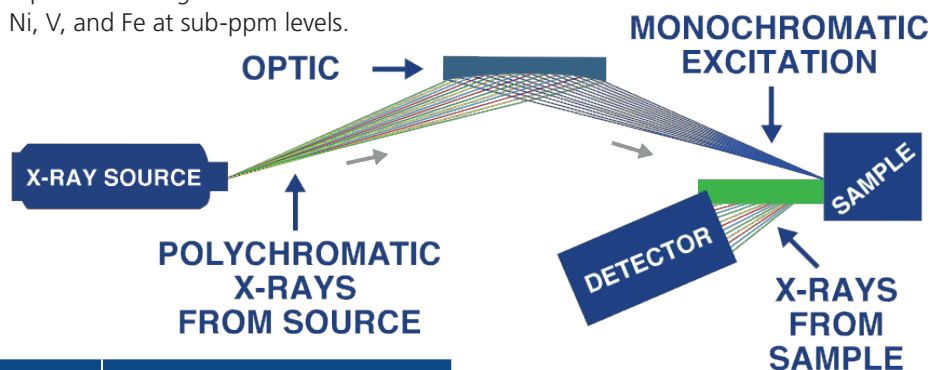

	HDXRF Sulfur Analyser	HDXRF Multi Element
Measured Elements	S	S, P, Cl, K, Ca, V, Cr, Mn, Fe, Co, Ni, Cu, Zn
Range (S)	2,6 ppm -10 wt%	5,7 -10 wt%
Other Ranges (x ppm - 10 wt%)	/	P : 17, Cl : 3, K : 0,7, Ca : 0,4, V : 0,1, Cr : 0,09, Mn : 0,07, Fe : 0,07, Co : 0,07, Ni : 0,04, Cu : 0,1 , Zn : 0,1
Measure Time	30 - 900 seconds	
Calibration	30 different calibration curves	
Sample Volume	7 ml	
Connections	USB, Ethernet	
Dimensions	36,8 cm x 41,9 cm x 15,3 cm	12,7 kg
Operating Temp.	5 °C - 40 °C	
Operating Humidity	30 - 85 %	

The graphic above shows the basic configuration of HDXRF and its use of focused monochromatic excitation. HDXRF reduces background noise and improves signal definition that enables lower limits of detection and dramatically better precision.

### Ordering Information

OTK-CT-11226

#### HDXRF Sulfur Analyser

Elements: S

OTK-CT-11225

#### HDXRF Multi Element Analyser

Elements: S, P, Cl, K, Ca, V, Cr, Mn, Fe, Co, Ni, Cu, Zn

## Insoluble



**Insolubles are a build up in combustion engines due to the burning fuel in the engine. They are combustion related debris and oxidation products within the lubrication oil.**

Regular monitoring of insoluble helps to prevent lacquer formation on hot surfaces, sticking of piston rings, wear of cylinder liner and bearing surfaces.

The detergent property of the oil will also decrease, speeding further deterioration.

- Detect insoluble from diesel engine combustion such as partially oxidized fuel, carbon, fuel ash, oil oxidation products and used lubricant additives.
- Simple and quick to use even for untrained people.
- The insoluble tests give you actionable results, helping to maintain your engine.

The **CMT Electronic Insoluble Test** is a self-contained device to test insolubles and soot in your engine oil.

It is suitable for all combustion engine oils regardless of the fuel in use.

It contains the latest technology to provide excellent repeatability and rapid results in the field.

Visible light is used to test the oil for soot and insoluble.

Just add one drop of your well mixed oil sample into 10 ml reagent and present the sample tube to the device.

The measuring range is detected automatically and the result is presented within seconds.

The **CMT Insoluble Spot Test Kit** is a simple spot test on a specially developed filter paper to get an indication of both, the insoluble load and the dispersancy of your lubricant.

Just drop one drop onto the paper and wait for the paper to dry. Just compare the filter paper with the pictures in the manual provided with the test.



Electronic Insolubles Console

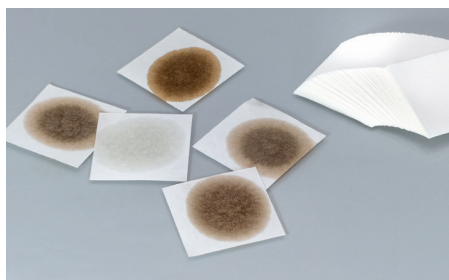

Insolubles Test Kit

### Ordering Information

OTK-CT-11205

#### Electronic Insoluble Test

Range:	0-2.4 Vol%
Accuracy:	Typically +/-0.1 %
Test Time:	< 2 minutes
No. of Tests:	30 Tests
Reagents:	non hazardous
Reagent Pack:	OTR-CT-12007

OTR-CT-12007

#### Insoluble Reagent Pack

No. of Tests:	30 Tests
Reagents:	non hazardous

OTS-CT-13021

#### Spare Insoluble Console

OTS-CT-13029

#### Glass Vial Consumables Pack (100)

OTK-CT-11002

#### Insoluble Spot Test Kit

Range:	good / poor
Test Time:	one hour (unattended)
Reagent:	non hazardous

## Salt Water Contamination

**For sea-water cooled systems on older vessels it is essential to know the source of the water in the oil. The CMT Salt Water Test does allow the user to identify whether the water contamination of the oil is sea- or freshwater. Use the Salt Water Contamination Test together with the Electronic Water in Oil Kit to identify the problem clearly.**

Especially in four-stroke engines water evaporates over time but the salt stays in the oil resulting in corrosion problems.

- Provides a fast indication if salt is present, even if all the water has been evaporated already.
- Fast and easy to understand results within minutes.
- Usable for all oils

### Ordering Information

OTK-CT-11003

#### Salt Water Contamination Test Kit

Range:	go / no go
Application:	Lubricating oil, fuel, water
Test Time:	1 hour (unattended)
No. of Tests:	25
Reagents:	Non hazardous

## Acid Number (AN)



Electronic Acid Number Console



Acid Number Drop Test Kit

**Acid Number or AN is an important oil parameter for hydraulic systems and gas engines. It is a measure of the organic and inorganic acids present within the oil.**

Maintaining the acid level of an oil prevents unexpected oxidation problems.

- The test kit is supplied with all reagents needed for 25 tests.
- Titration point can be observed with the help of an advanced electronic console.
- Providing you with easy to interpret results, suitable for use by untrained personnel.

Two versions are available. An economical and easy to use **Acid Number Drop Test Kit**. Just count the drops you need to get a colour change and get your reading from a table provided.

Alternatively we offer our **Electronic Acid Number Test Kit** which gives highest accuracy in the same measuring range.

### Ordering Information

OTK-CT-11209

#### Electronic Acid Number Test Kit

Range:	0-6 AN
Accuracy:	+/- 0.1 AN
Test Time:	2 minutes
No. of Tests:	25
Reagents:	hazardous components

OTR-CT-12008

#### Acid Number Reagent Pack

No. of Tests:	25
Reagents:	hazardous components

OTS-CT-13022

#### Spare Acid Number Console

OTS-CT-12008

#### Acid Number Test Reagent Pack

OTS-CT-13029

#### Glass Vial Consumables Pack (100)

OTK-CT-11001

#### Acid Number Drop Test Kit

Range:	0-6 AN
Accuracy:	+/- 0.3 AN
Test Time:	2 minutes
No. of Tests:	25
Reagents:	hazardous components

## Flash Point Tester

**The CMT Flash Point Tester is an automated closed cup instrument using just a 2 ml sample size.**

Increased flash point in engine oils to about 200°C is an early indication for fuel dilution which can result in crankcase explosion.

The flammability of a material also determines its safety classification and the regulations under which it must be handled, stored and transported.

The **Electronic Flash Point Tester** is a compact, bench top / portable, Closed Cup Flash Point Tester designed to carry out 'flash / no flash' tests or to determine flash point values up to 300°C using either Ramp or Rapid Equilibrium methods.

The operating principle is that a cup containing the sample to be tested is electrically heated in a ramp function to automatically increment the temperature for repeated tests until a flash is



observed, or the end of the search range is reached, allowing rapid determination of samples.

The device also features a user-friendly yes/no test. It is heated to a user set test temperature. At the set temperature, a shutter in the lid is opened and a test flame is dipped into the vapour space above the sample. It can be determined if a sample has a flash point above or below the test temperature by detecting whether a flash has occurred or not.

### Ordering Information

OTK-CT-11204

#### Electronic Flash Point Tester

Temp Range:	Ambient temperature (+5) to 300°C
Sample Size:	2-4 ml
Test Time:	OK in 2 minutes
Temp Ramping:	2° C/min.
Test Method:	Closed Cup
Resolution:	0.5°C
Accuracy:	0.5°C
Flash Detection:	Automatic
Voltage:	110-250 V
Frequency:	50/60 Hz
Power:	200 W
Weight:	4,3 kg

**Note:** A standard butane (lighter) refill cartridge is required for operation.

OTR-CT-11000

#### Test Kit Cleaner (250 ml)

## Fuel Bacteria Test

**Bacteria, moulds and yeasts can all grow rapidly in fuel tanks! Free water, warmth and condensation in the fuel form the basis for growth of the Diesel Bugs.**

Standard grades of diesel are clear and usually light yellow. The smallest discoloration can be a sign of the Diesel Bug. To be sure, you have to test it!



The addition of environmentally friendly biodiesel to the fossil diesel offers microbes an excellent source of nutrition. Microbes grow more than ever and form increased amounts of "biomass". This leads to clogged filters, corrosion and to engine failure.

The CMT **Fuel Filter Bacteria Tests** can be used to test the Diesel Fuel for bacteria. The Dip Slide Test is used in case of a clogged filter. A thin film of the residues from the clogged filter can be incubated on the dip slide to evaluate if the filters clogging because of bugs or other dirt.

### Ordering Information

OTK-CT-11006

#### Fuel Filter Bacteria Test (Dip Slides)

Range: low / moderate / heavy  
 Test Time: 24 - 48 h at 27 - 30°C  
 1-4 days at ambient temperature  
 No. of Tests: 10

### The Fuel Filter Bacteria Test:

- provides evaluation of Diesel Bug count (bacteria, yeast and moulds altogether).
- Easy to use.
- Provides precise and reliable result.
- Allows fast and safe handling.
- Suitable for all qualities of diesel fuel inclusive biodiesel.

## Reagents and Consumables

**Produced under strict ISO guidelines (DNV GL certified) CMT's reagents and consumables can be used for nearly all test kits on the market regardless of the manufacturer.**

All reagent packs contain necessary consumables as well and are therefore user friendly.

Also packing innovations like the pre portioned sachets of the Water in Oil Reagent B make the usage of the reagents as easy as possible for the user on site.

Also as part of the reagent & consumables range CMT supplies cleaning agents.

A Test Kit Cleaner for cleaning and maintaining the individual test devices and a vial cleaner for cleaning glass materials used in optical measurements can be ordered from us.



### Ordering Information

OTR-CT-12001

#### Water in Oil Reagent Pack

No. of Tests: 50 Test

OTR-CT-12002

#### Base Number Reagent Pack

No. of Tests: 50 Test

OTR-CT-12007

#### Insolubles Reagent Pack

No. of Tests: 30 Test

OTS-CT-12005

#### AN Reagent Pack 0-3

No. of Tests: 50 Test

UN: UN1993

OTR-CT-12006

#### AN Reagent Pack 0-6

No. of Tests: 50 Test

UN: UN1993

OTR-CT-11000

#### Test Kit Cleaner

Size: 250 ml

OTR-CT-12010

#### Vial Cleaner

Size: 250 ml

## Cold Filter Plugging Point / Pour Point



The wax-like solidification of fuel when exposed to low temperatures determines its temperature usability boundary. The relevant indicator for that is the CFPP (Cold Filter Plugging Point).

To prevent that the fuel blocks filters due to insufficient cold resistance it is important to know the CFPP.

CMT's test kit allows a quick and easy determination of the temperature boundary above which it is safe to use the fuel. In addition it allows to measure the pour point.

### Your benefits:

- Cheap compared to available lab and electronic devices
- Usable for untrained personnel
- No complex parts guarantee a long service time

### Ordering Information

OTK-CT-11212

#### CFPP / Pour Point Test

Range: - 10°C to 10°C

Test Time: 10 minutes

No. of Tests: 20

## Export-Tool

The Export Tool is a powerful software tool which allows the download and evaluation of measured data from all devices of our newest generation

The software exports stored data from our electronic devices (with enabled Download Option) when connected to a PC via an USB connection.

Exported data can be added to older exported values so that trending becomes an easy thing.

Furthermore, it offers an integrated graphic data evaluation module which helps bringing the data to life.

This makes the evaluation much easier and quicker. Multiple indicators can be displayed by the software allowing a comprehensive overview of the equipment tested.

### Your benefits:

- Save all readings to create a comprehensive trend on your computer
- Evaluate your measurements with the Export Tool
- Graphic display of the values for easy trending and identification of problems
- Adjustable graphs allow to customize the display as per your needs
- Detect even slow developing performance issues and impending damages

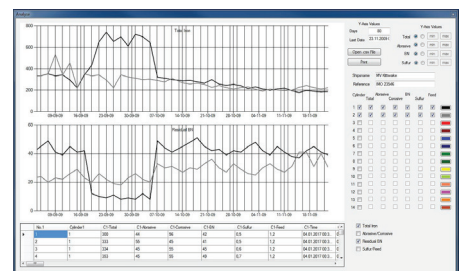
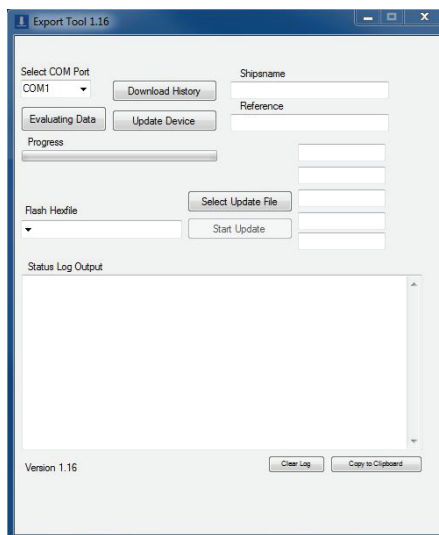

### Ordering Information

SW-C00002-CT

#### Download Option Console

SW-C00004-CT

#### Download Option TouchCell

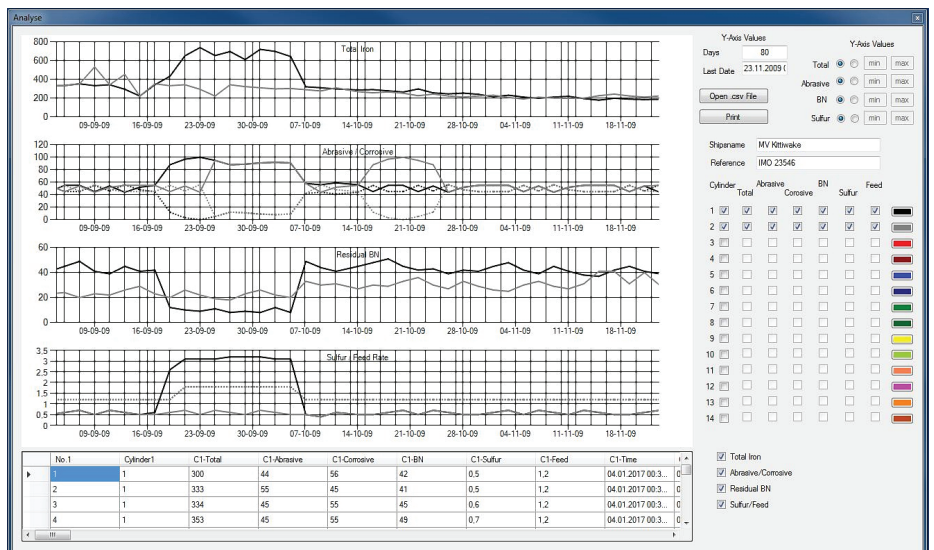

## 2. Cylinder Drain Oil Management

### Overview

**While in the past abrasive wear was the predominant wear mechanism creating problems like scuffing or sudden severe wear these days corrosive wear has become the predominant wear in the new generation of engines, whereas abrasive wear is no longer the predominant problem for the new generation of engines.**

Main parameters influencing the corrosive wear in the combustion chamber are the sulphur in the fuel, part load optimisation such as T/C-cut out, the load pattern and naturally the lubrication rate and the BN level of the cylinder oil. The corrosive wear will be indicated by the BN values and the iron content of the drain oil from the cylinder lube oil.

Sulphuric acid forms during the combustion of sulphur containing fuels. The sulphuric acid may condensate on the cylinder liner wall depending on the temperature of the wall and the pressure in the cylinder. In modern engines the dew point of sulphuric acid may be as low as 280°C leading to a higher amount of acid condensation compared to an older design engine with the same fuel consumption.

The measured BN in the drain oil is an indication of the oils remaining ability to neutralise this acid. A low BN value indicates that the oils alkalinity reserve is close to exhaustion and therefore the protection of the engine from the acid corrosion might be insufficient. The concentration of iron

particles in the oil is composed of the abrasive wear and the corrosive wear. It is important to monitor both parameters, BN and iron content closely to avoid damage to the cylinder liner.

Laboratory oil analysis provides a detailed insight into the engines condition at the time of sampling. Until the sample report has arrived on the vessel a considerable amount of time may have passed due to the logistics of landing and sending the sample and later the analysis itself.

Furthermore, laboratory oil analysis can only be done in longer time intervals. With permanently changing conditions in the engine just a laboratory oil analysis would not offer in time enough insurance that a reduced feed rate does not harm the engine.

**The CMT Cylinder Drain Oil Service does consist of two important major components:**

- **Frequent on board oil tests of BN (base number) and iron content.** For the on board iron measurements, it is essential to measure all the iron – both iron from corrosion and from abrasion and adhesion.
- **Periodical onshore independent laboratory oil tests** providing a complete result about wear, contamination, oil condition and additives together with a diagnostic statement from our tribology experts.

Iron (Fe) total [mg/kg]

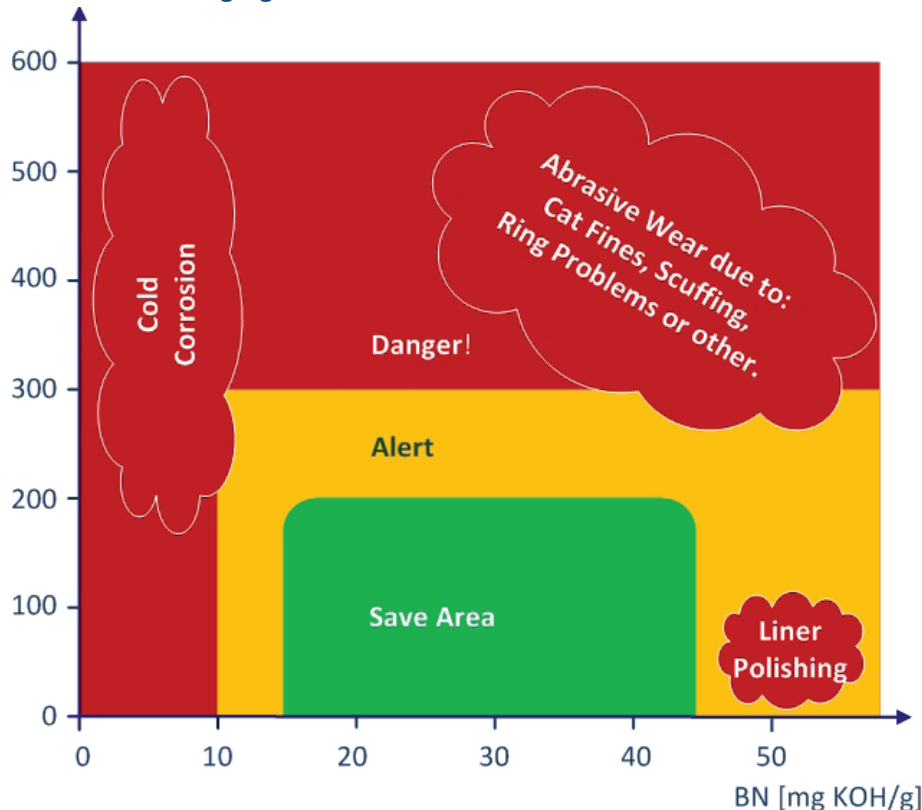

Taking a cylinder drain oil sample from the scavenge space.

This chart shows the relation between total iron content and remaining BN in the drain oil from the scavenge space.

**By analysing scrape down oil collected from the scavenge space shipboard personnel are able to monitor the condition of the engine's cylinders, avoid corrosive or abrasive wear by means of launching corrective actions and detect changes as they occur.**

In order to monitor wear conditions in an engine, with minimum delay between sampling and diagnosing a situation of high wear, on-board test kits are available to detect abnormal wear and therefore enable the operator to take immediate corrective action to increase the lubricant feed.

The **Electronic Drain Oil Analysis Kit** includes an easy to perform BN- and iron test kit allowing to measure the magnetic and corrosive iron separate. It provides quick results of the drain oil's most important properties relative to the engine's cylinder operating condition.

Taking that in mind it becomes obvious, that a frequent onsite analysis of the most important parameters becomes necessary together with a regular laboratory oil test in case you aim to reduce the feed rate and at the same time want to limit the risk of a liner wear problem.

Besides measuring the remaining alkalinity reserve and possibly some other oil condition indicators like water and viscosity in the scrape down oil it is crucial to measure the wear rate if you are optimizing the feed rate. Since there is no fixed optimum it is necessary to have the possibility to measure the iron content on a very frequent base.



On-site Drain Oil Analysis Kit

**On board oil tests are designed to measure only single parameters. Use them as an essential supplement to the Laboratory Oil Test - not as a substitute. A comprehensive laboratory oil analysis together with the frequent onboard test is essential as part of an effective cylinder drain oil monitoring.**

## Ordering Information

OTK-CT-11230

### Cylinder Drain Oil Analysis Kit

#### 1) Iron II SM Test

Range: 50 - 1500 ppm  
 Corrosive iron: 0 - 100 % of total  
 Abrasive iron: 0 - 100 % of total  
 Accuracy: +/- 20 ppm  
 Repeatability: 10 ppm  
 Test Time (ave.): 3 min. per Test  
 No. of initial Tests: 50  
 Memory: last 20 reading / cyl.  
 14 cylinders  
 Reagents: non hazardous

#### 2) CDO Alkalinity Reserve (BN) Test

Range: 1-180 BN  
 Accuracy: +/- 5% of new oil BN  
 Number of Tests: 50  
 Test Time: 5 minutes  
 Memory: last reading  
 Reagents: non hazardous

LAB-CT-17601

### Laboratory SDA Drain Oil Analysis

OTS-CT-13034

### Iron Test II Reagent Pack

No. of Tests: 50 drain oil samples  
 Reagents: non hazardous

OTS-CT-13029

### Glass Vial Consumables Pack (100)

OTR-CT-12002

### Base Number Reagent Pack

No. of Tests: 50  
 Reagents: non hazardous

OTR-CT-11000

### Test Kit Cleaner (250 ml)

Size: 250 ml  
 Reagent: non hazardous

OTR-CT-12010

### Vial Cleaner

Size: 250 ml  
 Reagent: non hazardous

OTS-CT-13035

### Electric Shaker

OTS-CT-13027

### Spare CDO BN TouchCell

SW-C00002-CT

### Download Option Console

License for Data download

SW-C00004-CT

### Download Option TouchCell

License for Data download

The main indicator for wear in 2 stroke diesel engines remains iron. Testing cylinder drain oil for iron content and residual base number (BN) is a very commonly applied technique for screening drain oil samples on-board seagoing vessels. CM Technologies now introduces a complete new technology for testing Iron onsite. The new & improved Iron Test has become much faster, easier and much more accurate than anything else currently available.

The newly patented CMT **Iron Test II** is based on a simple two component wet chemistry which is tested in an electronic photometer. An electric shaker will assist the user to perform the test.

The simple test procedure just takes 3 minutes to achieve an accurate iron test result. For higher iron readings the user can do a second test to test for corrosive iron only. This will provide the values for total, corrosive and abrasive iron.



Iron glass vial after filtration

Monitoring of the iron content in the cylinder drain oil and the launching of remedial actions in due time can help to avoid cold corrosion and unnecessary abrasive wear in the cylinder liner.

Together with the CMT **CDO BN Test Kit** the **Electronic Iron Analysis Kit** allows to monitor the most important parameters of the drain oil on site providing the user with the necessary information to optimize the feed rate of the cylinder oil and at the same time to avoid unnecessary wear of the individual cylinder liners. Both kits are also available as a combined CDO Test Kit.

CMT also offers a complete Cylinder Drain Oil Service which includes the onsite **CDO Test Kit** and a periodical onshore independent laboratory oil analysis providing complete results about wear, contamination, oil condition and additives together with a diagnostic statement from our tribology and engine experts.

### Ordering Information

OTK-CT-11228

#### Electronic Iron II SM Test Kit

Range:	50 - 1500 ppm
Corrosive iron:	0 - 100 % of total
Abrasive iron:	0 - 100 % of total
Accuracy:	+/- 20 ppm
Repeatability:	10 ppm
Test Time (ave.):	3 min. per Test
No. of initial Tests:	50
Memory:	last 20 reading / cyl. 14 cylinders
Reagents:	non hazardous

SW-C00002-CT

#### Download Option Console

License for data download

OTS-CT-13034

#### Iron II Test Reagent Pack (Version II)

No. of Tests:	50 drain oil samples
Reagents:	non hazardous

OTS-CT-13024

#### Iron Test Reagent Pack (Version I)

No. of Tests:	50
Reagents:	non hazardous

OTS-CT-13029

#### Glass Vial Consum. Pack (for S/N > 400)

Glass Vials with cap: 100

OTR-CT-12010

#### Vial Cleaner

Size	250 ml
Reagent:	non hazardous

OTS-CT-13025

#### Iron Test Consumables Pack (Version I)

Glass Tubes (blue caps):	24
Set of Syringes	

### Your benefits:

- Greatly increased repeatability and accuracy (+/- 20 ppm)
- Differentiation between corrosive and abrasive iron
- No soot dependence of the test allows for most reliable results
- Fastest onsite wet chemistry test
- Intuitive usage due to touch screen functionality
- Large memory for storing data
- Easy trending thanks to a high resolution graphic display
- Simple USB data transfer to a PC
- No hazardous chemicals involved

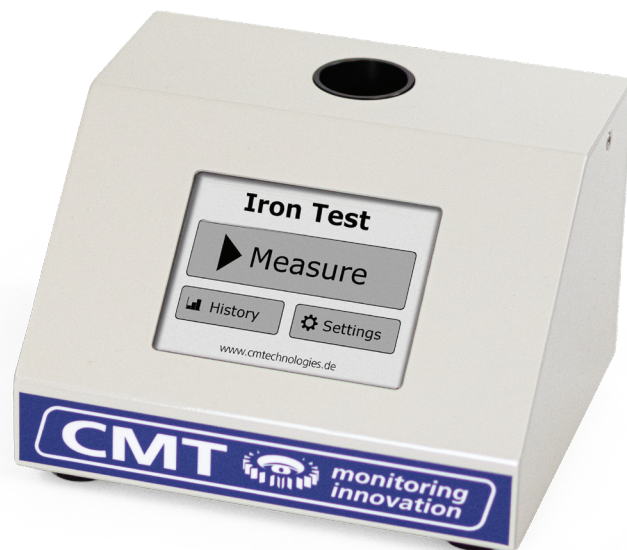

Iron Console

## Cold Corrosion

**Cold corrosion is a type of corrosion resulting from condensation of sulfuric acid on the liner walls and which deteriorates the liner surface. CMT has developed a reagent based test to measure the level of corrosive wear.**

Corrosive iron in the cylinder oil indicates a chemical wear of the liner of your engine. Cold corrosion is the most serious in modern engine designs and earlier engine designs that have been modified for part-load or low-load operation.

With the **Cold Corrosion Test Kit** you will be in control and can determine the severity of the acid corrosion of your engine.



Our **Cold Corrosion Test Kit** has been designed specifically to be fast, reliable and simple.

It will give results within 20 minutes that are easy to interpret via the supplied comparison sheet.

Testing the cylinder oil for corrosive iron is the most reliable source of control.

### Ordering Information

OTK-CT-11232

**Cold Corrosion Test Kit**

Range: 50 - 800 ppm

## Ferrous Wear Debris Meter

**Testing lubricant samples for ferrous wear debris is an established method to detect developing and impending damages as well as gaining knowledge about the wear life cycle of the tested equipment. CMT's newest development - the Ferrous Wear Debris Meter - is an accurate, easy-to-use solution for offline and at-line measurements of ferrous wear debris concentrations.**

Gain the insight necessary to determine the condition of your equipment. Applicable for diverse applications like Cylinder Drain Oil of 2-stroke diesel engines gearboxes or other machinery.



The **Ferrous Wear Debris Meter** provides repeatable and accurate determination of ferromagnetic material concentration down to single ppm levels.

It provides a mass proportional output from any size or quantity of ferrous contaminant particles, even sub-micron particles. Particle size does not affect the measurement (in contrast to spectrometric methods). Readings are unaffected by properties (dielectric) of fluid base, or additive package, or water content. Readings are straightforward and are presented in ppm.

### Ordering Information

OTK-CT-20500

**FWDM Ferrous Wear Debris Meter**

Range: 0 - 2000 ppm  
Resolution (ferrous): down to 1 ppm  
Repeatability: +/- 10 ppm typically  
Power supply: 12 V DC @ 250 mA  
Weight (device): 485 g  
Test time: 1 second

OTS-CT-13039

**FWDM Consumables Pack**

No. of 2 ml Test tubes: 250

**Patent**

(No. 2910933)

**On-Site Drain Oil Analysis Kit**



CDO BN TouchCell

**The Cylinder Drain Oil Analysis Set consists of two different tests:**

- Analysis of the total iron content (corrosive and abrasive)
- Analysis of the remaining alkalinity reserve compared to the fresh oil alkalinity.

Parameters like Water, Viscosity and others can be measured with our portable On-Site Oil Test & Analysis solutions.



CDO Total Iron II Test

**Feed Rate Optimization**

Optimization means reducing to the minimum level which still ensures good lubrication and at the same time sufficient neutralisation of combustion related acids. Minimum level also means having enough oil to clean the piston surface. Even current standard electronic lubrication systems are based only on experience and standard inputs as rpm or the sulphur level of the fuel. Currently there is no system available which provides a feed back about the current liner condition. As one of the engine's largest overheads, an average container ship can spend \$8 million and more on cylinder lubrication in its life time. Depending on the vessels trade, engine load, engine running hours and other factors, constant monitoring is a vital tool in optimising cylinder lube oil feed rate and, as a result, improving efficiency, decreasing lubricant costs and avoiding issues related with over and under lubrication.

Engines are regularly over lubricated in an attempt to avoid problems including scuffing, but this practice not only causes high lubrication costs, it can sometimes lead to associated problems such as bore polishing. Therefore, although optimising cylinder lubricant usage is one method of achieving commercial advantage, there is a point where savings can be eroded by increased maintenance costs.

**Practical approach:**

If the BN value in the drain oil is too low or the iron content is too high, the cylinder lube oil feed rate must be increased.

If the BN value is high and the iron content is low, the cylinder lube oil feed rate may be decreased.



**Rapid Return of Investment**

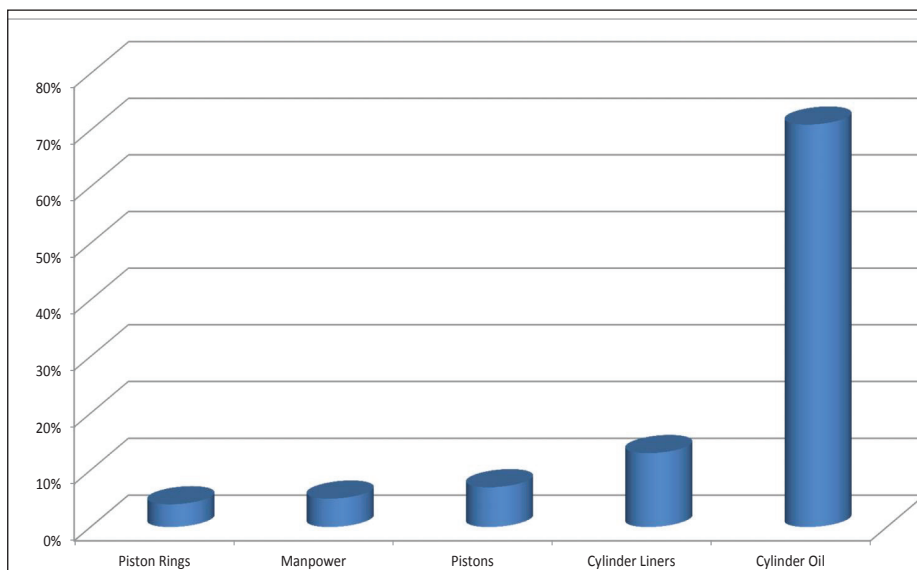

This chart shows that the cost of cylinder oil and the liner itself are the biggest cost factors when operating a main engine. Existing installations have proved that significant cost savings can be achieved with return on investment achieved in less than a year in some cases. .

## Cylinder Drain Oil Laboratory Oil Service

Laboratory scrape down oil analysis from CMT provides comprehensive testing of the oil samples with a full set of data and a diagnostic statement from a tribology engineer.

- 100 ml sample-bottle (prepaid)
- Addressed envelope to return the sample bottle to our lab
- Sample Information Form with barcode label
- Laboratory tests: All samples are analysed and diagnosed by the end of the next business day. (As long as the samples arrive at our laboratory before noon, in our prepaid sample bottle with a correctly filled out sample information form).
- Laboratory report complete with a highly detailed diagnostic statement (prepared by a mechanical engineer)
- Dispatch of the laboratory report via mail, email, fax or data-file
- Online-recall of all laboratory reports and analysis data



Source: Oelcheck GmbH

**You will get a detailed lab report completed with a very detailed diagnostic statement prepared by a tribology engineer. It will be an one page report per sample with a simple rating system which quickly alerts you to problems with your oil or equipment.**

There is no need for you to work through a long report of several pages. The report contains a historical look at the last 4 samples with the complete history available from our web server (including trend graphs). If you have any questions relating to your report or equipment you can call one of our service engineers to discuss your results and provide advice. The lab report will be sent to you by mail, email or fax as agreed with you.

**It is possible to get the current lab reports even faster and to have, at the same time, a comparison with earlier analysed samples.**

If you require your results sooner, instead of waiting for an e-mail, fax or mail you can directly log on to our fire wall protected web server. Where, as soon as we have evaluated your sample, we inform you by e-mail that the results are available. You can see the analysis results in the original version of the lab report and print it or forward it to interested parties.

**This service offers you to:**

- Easily check online data entry for new samples
- Quickly view of all your samples
- Check sample status
- Display all lab reports
- Translate lab reports into different languages
- Forward lab reports via e-mail
- Graphically view trend analysis values for individual samples
- Display of the IR spectrum and other diagrams
- View photos of the sample and the inside of the cap / lid
- View photos of the spot test, solid contaminants and much more

### Ordering Information

LAB-CT-17601

**Laboratory SDA Drain Oil Analysis**

# SDA Laboratory Report

## SDA LAB REPORT

IMO number: **IMO XXXXX**  
 Vessel name: **MS OELCHECK**  
 Component: **2 stroke marine diesel engine**



OELCHECK GmbH · Postfach 1116 · 83094 Brannenburg

Typical Laboratory Report  
 OELCHECK  
 Postfach 1116  
 83094 Brannenburg

Customer number: 2631100      Total operating hrs: 24507 h  
 Manufacturer: XXXX      Engine model: XXXX  
 Engine load: 77 %      Engine speed: 79 rpm  
 All turbochargers in operation: Yes      Scavenge air temperature:  
 Ambient temperature: 45 °C      Humidity: 42 %  
 Longitude: 41° 26.6 min W      Latitude: 23° 50.2 min S  
 Fuel grade: RMK380      Fuel viscosity: 325.7 cSt  
 Fuel sulphur content: 3.1 %      Fuel Al-Si content: 23 mg/kg  
 Fuel vanadium content: 87 mg/kg  
 Oil brand name: XXXXX XXXXXXXXXX XXX  
 System oil: XXXXXXX XXXXXXXXXX XXX  
 Date sample taken: 01.07.2014      Date tested: 08.07.2014  
 Contact: OELCHECK      Phone number: 0049-8034-9047-210

Page 1 of 4

### Diagnosis for the current laboratory values

Residual BN is adequate to avoid corrosion but low on cylinders 3 and 7. A feed rate increase on cylinders 3 and 7 is recommended to ensure that corrosion is controlled. Residual BN is not high enough on some cylinders to safely recommend a feed rate reduction. Iron, Chrome and Copper are in the normal range. PQ Index is higher than expected for cylinders 1, 3, 4 and 5 but not critical. Vanadium and nickel contents are high but not a cause for concern. Soot contents are all low and well within the expected range. System oil content in cylinders 2 and 4 is high as are the copper contents. This could indicate wear of the stuffing box seals. Viscosity at 40°C is relatively high but does not require attention. I recommend that you send the next sample for trend observation in line with the recommendation of your engine supplier or your insurance company.

### Average rating



Action

Recommendation: Please complete all sample information in future, this allows a more detailed assessment to be made.  
 Dipl. Wl-Ing. (FH) Steffen Bots

### ANALYSIS RESULTS

LAB NUMBER	1702922	1702923	1702924	1702925	1702926	1702927	1702928
CYLINDER NUMBER	Average	1 of 7	2 of 7	3 of 7	4 of 7	5 of 7	7 of 7
SAMPLE RATING	!	?	!	!	?	✓	!

### PREVIOUS SAMPLE RATING

08.07.2014	!	✓	✓	?	?		
24.06.2014	!	✓	✓	!	!	✓	!
24.06.2014	!	✓	✓	!	!	?	?

Feed rate	g/kWh	0.9	0.8	0.8	0.8	0.8
-----------	-------	-----	-----	-----	-----	-----

### WEAR

Iron	Fe mg/kg	92	78	136	122	93
Chrome	Cr mg/kg	5	7	8	10	5
Copper	Cu mg/kg	3	2	6	5	5
PQ index		30	27	< 25	29	28

### CONTAMINATION

Silicon	Si mg/kg	103	108	136	113	90
Aluminum	Al mg/kg	23	24	39	29	23
Sodium	Na mg/kg	120	105	162	163	127
Nickel	Ni mg/kg	178	156	259	240	183
Vanadium	V mg/kg	591	527	841	801	597
Sulphur	S mg/kg	28370	26720	34149	31904	28574
Water	%	2.11	2.62	2.14	2.40	2.06
Soot content	%	0.1	0.2	< 0.1	0.1	< 0.1
Excess system oil > 20%		18.7	11.9	32.5	16.9	26.9

### OIL CONDITION

Viscosity at 40°C	mm <sup>2</sup> /s	486.44	431.89	549.15	597.91	480.15
BN	mgKOH/g	27.62	54.90	31.70	17.81	24.69

### ADDITIVES

Calcium	Ca mg/kg	25270	23282	23856	22975	24500
Magnesium	Mg mg/kg	114	127	159	132	114
Zinc	Zn mg/kg	187	180	242	189	186
Phosphorus	P mg/kg	29	19	52	27	43



## SDA LAB REPORT

IMO number: IMO XXXXX  
 Vessel name: MS OELCHECK  
 Component: 2 stroke marine diesel engine  
 Manufacturer: XXXX      Engine model: XXXX  
 Oil brand name: XXXXX XXXXXXXXXX XXX  
 System oil: XXXXXXX XXXXXXXXXX XXX  
 Contact: OELCHECK      Phone number: 0049-8034-9047-210



Page 2 of 4

### FOUR SAMPLE TREND

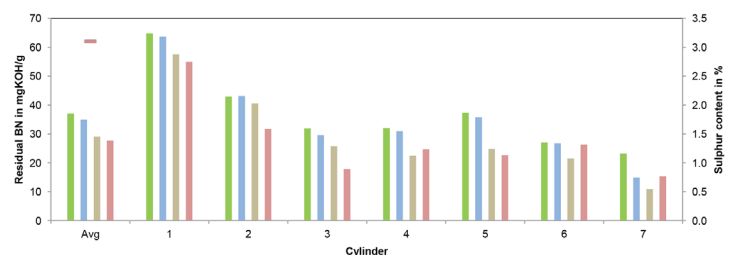
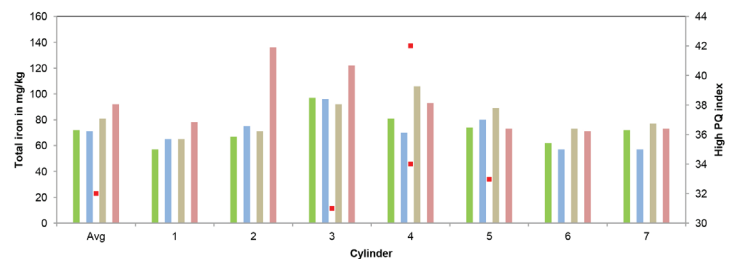
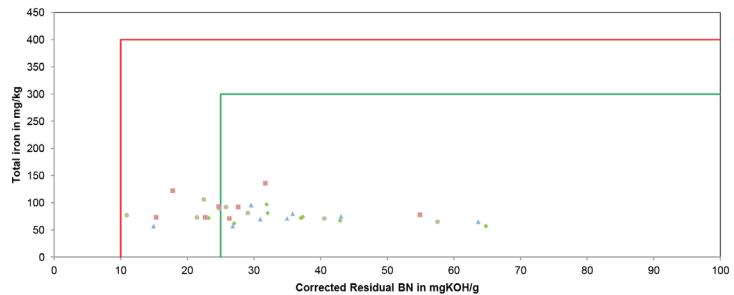
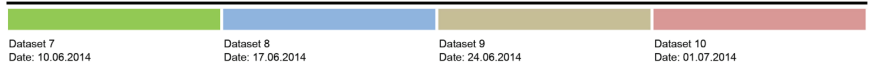

The CMT SDA laboratory report in cooperation with OelCheck is a compact data set showing the complete details for all cylinders. Even at first glance, it provides essential information about where action needs to be taken.

A matrix provides further information about the state of the cylinder oils, the lubricant feed rate in each cylinder, additives and alkalinity reserve, viscosity and abrasion, as well as other impurities such as cat fines, water, soot, silicon and metals such as nickel and vanadium.

Under a separate heading, the values for iron particles, chrome, copper and the PQ index (value for magnetic iron particles) are shown as important indicators of any wear.

Diagrams will illustrate the results as a trend. An experienced diagnostic engineer proposes further measures in an Individual comment.

The new **SDA laboratory report** contributes substantially to the cost-effective and reliable operation of your engine. The informative laboratory reports are prepared in a clear and well structured form.

They contain not only the data for the current samples, but also the values of up to the four previous examinations. This provides the user with a basic overview of the operation of the engine and the performance of the cylinder oil.

# SDA LAB REPORT

IMO number: IMO XXXXX  
 Vessel name: MS OELCHECK  
 Component: 2 stroke marine diesel engine  
 Manufacturer: XXXX Engine model: XXXX  
 Oil brand name: XXXXX XXXXXXXXXXXX XXX  
 System oil: XXXXX XXXXXXXXXXXX XXX  
 Contact: OELCHECK Phone number: 0049-8034-9047-210



Marie-Curie-Str. 5 • 25335 Elmshorn • Germany  
 Phone +49 41 21 700 890 • info@cmttechnologies.de



Page 3 of 4

## FOUR SAMPLE TREND

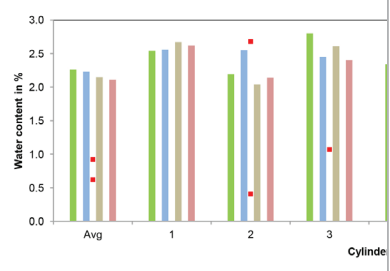
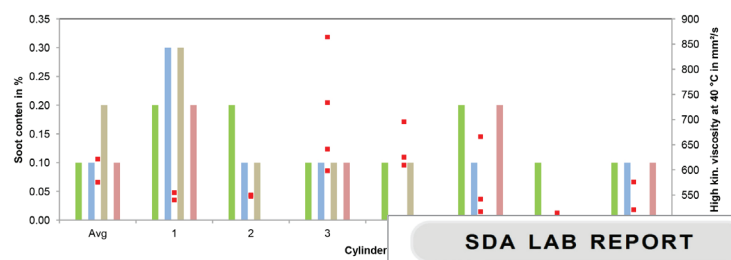
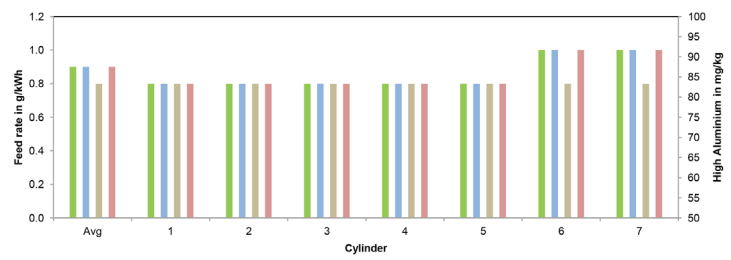
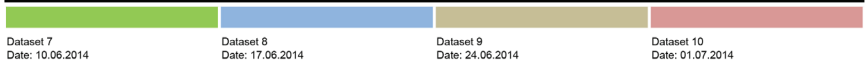

# SDA LAB REPORT

IMO number: IMO XXXXX  
 Vessel name: MS OELCHECK  
 Component: 2 stroke marine diesel engine  
 Manufacturer: XXXX Engine model: XXXX  
 Oil brand name: XXXXX XXXXXXXXXXXX XXX  
 System oil: XXXXX XXXXXXXXXXXX XXX  
 Contact: OELCHECK Phone number: 0049-8034-9047-210



Marie-Curie-Str. 5 • 25335 Elmshorn • Germany  
 Phone +49 41 21 700 890 • info@cmttechnologies.de



Page 4 of 4

## LONG TERM TREND

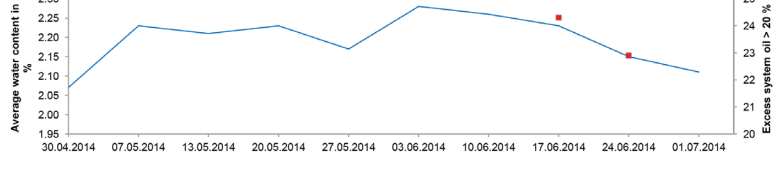
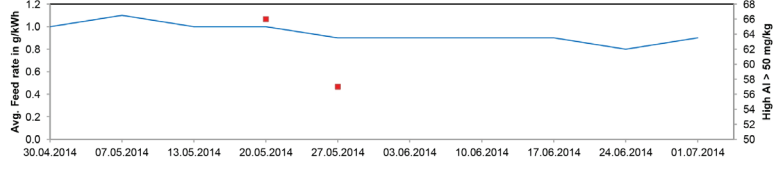
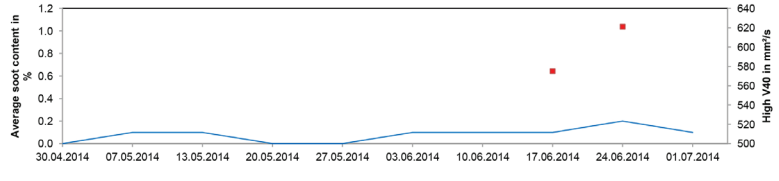
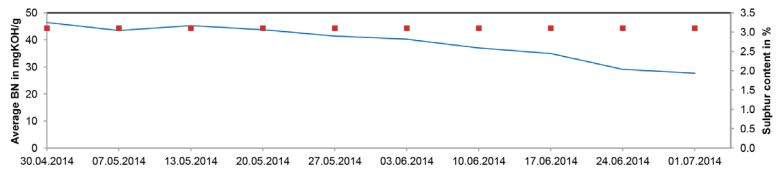
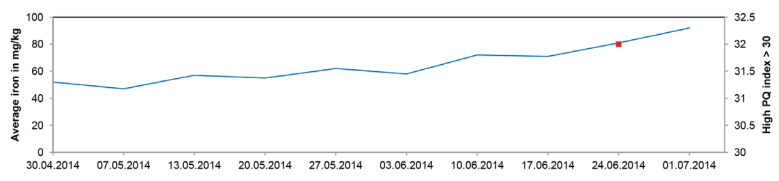

## 3. Independent Laboratory Oil Test

### Lubrication Oil Test Service

The oil itself is an excellent data medium which is full of valuable information if tested correctly and the findings actioned. This information highlights the condition of the oil and the machine, enabling you to identify the optimal moment for an oil change. Wear particles can be directly related or assigned to a damaged part of a given machine giving information of the condition of the plant and providing early warnings in the fight to reduce and prevent damage.

The CMT Marine Oil Test Service is a comprehensive insight into the functioning of your engine. It covers analysis of the combustion process, cylinder oil feed rates, fuel problems and identification of potential issues such as piston and liner wear, incomplete combustion and crankcase system oil analysis. In particular, we work very hard to minimize your costs related to oil consumption and feed rate. It is not in the interest of CMT to let you spend more on lubrication than necessary.

CMT has formed a strategic partnership with a certified and accredited laboratory with over 15 years experience in used oil lab analysis. A database of more than one million used oil samples from more than fifteen thousand customers all over the world and our cooperation with lube oil suppliers and engine manufacturers allows us to give you appropriate independent recommendations based on the oil analysis.

#### Typical applications for our independent marine oil lab service on board ships are:

Diesel Engine System Oil, Cylinder Drain Oil, Stern Tube Oil, Hydraulic Oil, Gear Box Oil and other Lubricants



#### Scope of analysis: (can vary with oil type)

Wear metals:	Iron, Chrome, Tin, Aluminium, Nickel, Copper, Lead, Molybdenum, PQ-Index
Contaminants:	Cat Fines (Aluminium / Silicon), Potassium, Sodium, Soot, Glycol, Fuel, Water %
Oil condition:	Viscosity @ 40° and 100°C including Viscosity-Index, Base Number (BN) Oxidation, Nitration, Sulfation, Sludge carrying properties
Additives:	Calcium, Magnesium, Zinc, Phosphor, Barium, Boron, Sulphur and Molybdenum

#### Ordering Information

LAB-CT-17599

**Independent Laboratory Oil Analysis**

#### The CMT service includes:

- 100 ml sample-bottle (prepaid)
- Addressed envelope to return the sample bottle to our lab
- Sample Information Form with barcode label
- Laboratory tests: All samples are analysed and diagnosed by the end of the next business day. (As long as the samples arrive at our laboratory before noon, in our prepaid sample bottle with a correctly filled out sample information form).
- Laboratory report complete with a highly detailed diagnostic statement (prepared by a mechanical engineer)
- Dispatch of the laboratory report via mail, email, fax or data-file
- Online-recall of all laboratory reports and analysis data
- Easily check online data entry for new samples
- Quickly view of all your samples
- Check sample status
- Display all lab reports
- Translate lab reports into different languages
- Forward lab reports via e-mail
- Graphically view trend analysis values for individual samples
- Display of the IR spectrum and other diagrams
- View photos of the sample and the inside of the cap / lid
- View photos of the spot test, solid contaminants and much more

**LAB REPORT**

Unit ID: **9122057**  
 Component: **W-01 Anchor/Mooring Winch-End. Gear SB**  
 Current sample number: **1347558**

**CMT**  
 monitoring systems

Vessel name: **Milena Bule**  
 Company: **Castrol**  
 Engine/Equipment maker: **Not reported**  
 Engine/Equipment type: **Marine Winch/ AFP SB**  
 Oil brand name: **Castrol Alpha SP 220**

Diagnosis for the current laboratory values  
 Iron has clearly increased. The PQ index indicates an increased amount of magnetic ferrous particles. The sample is heavily contaminated. Also, particles larger than 40 µm can be detected reliably without a microscope. The additive value differs from the fresh oil value recorded in our database. Possible reasons could be a different oil type or mixture with another oil type. I recommend that you change the oil as soon as possible if you have not already done so.

**Sample Rating**

**action**

**ANALYSIS RESULTS**

LAB NUMBER	Current sample	1347552	1229556	1229552
<b>SAFETY DATA</b>				
Date tested	18.03.2012	18.03.2012	22.05.2010	22.03.2010
Date of sample taken	18.03.2012	18.03.2012	18.10.2010	18.10.2010
Date of last oil change	18.03.2011	26.03.2011	18.10.2008	18.10.2008
Top-up since change	-	-	-	-
Opening time since change	-	-	-	-
Total operating hrs	-	-	-	-
Oil change	-	-	-	-
<b>WEAR</b>				
Iron	621	181	52	21
Chromium	0	0	0	0
Tin	0	0	0	0
Aluminium	0	0	0	0
Nickel	0	0	0	0
Copper	4	1	3	0
Lead	11	0	0	0
<b>PQ-Index</b>	82	OK	OK	OK
<b>CONTAMINATION</b>				
Sulfur	6	6	3	2
Phosphorus	2	0	0	0
Selenium	0	0	0	0
Lithium	0	0	0	0
Water	< 0.10	< 0.10	< 0.10	< 0.10
<b>OIL CONDITION</b>				
Viscosity at 40°C	166.81	222.27	216.04	155.10
Viscosity at 100°C	53.8	55	55	50
Viscosity index	158	95	95	100
Cloudiness	2	2	2	2
<b>ADDITIONALS</b>				
Calcium	126	221	24	31
Magnesium	2	0	0	0
Barium	200	200	200	200
Zinc	171	92	19	83
Phosphorus	200	200	200	200
Barium	0	0	0	0
Molybdenum	0	0	0	0
Sulfur	897	1218	1221	808

**Additional sample details**  
 Sample taken by: CIE

**Oil Condition**  
 Viscosity at 40°C: 166.81 mm²/s  
 Viscosity at 100°C: 53.8 mm²/s  
 Viscosity index: 158  
 Cloudiness: 2

**ADDITIONALS**  
 Calcium: 126 mg/kg  
 Magnesium: 2 mg/kg  
 Barium: 200 mg/kg  
 Zinc: 171 mg/kg  
 Phosphorus: 200 mg/kg  
 Barium: 0 mg/kg  
 Molybdenum: 0 mg/kg  
 Sulfur: 897 mg/kg

**Infra-Red Spectrum**

**Bottle and Cap**

**Internet:**

**It is possible to get the current lab reports even faster and to have, at the same time, a comparison with earlier analysed samples.**

If you require your results sooner, instead of waiting for an e-mail, fax or mail you can directly log on to our fire wall-protected web server. Where, as soon as we have evaluated your sample, we inform you by e-mail that the results are available. You can see the analysis results in the original version of the lab report and print it or forward it to interested parties.

**LAB REPORT**

Unit ID: **9122057**  
 Component: **M-01 Main Engine (2-stroke) System Oil**  
 Current sample number: **1347574**

**CMT**  
 monitoring systems

Vessel name: **Milena Bule**  
 Company: **Castrol**  
 Engine/Equipment maker: **Not reported**  
 Engine/Equipment type: **ME RTA 62U**  
 Oil brand name: **Castrol CDX 30**

Diagnosis for the current laboratory values  
 The wear metals are only slightly increased. Soot might occur if normal. The water content is too high. It shows the permitted limit value. This viscosity has increased. Please note that excessive water may cause corrosion and/or oxidation. I recommend that you remove the water from the oil using suitable methods. Otherwise the oil should be changed.

**Sample Rating**

**action**

**ANALYSIS RESULTS**

LAB NUMBER	Current sample	1347421	1347788	1347795
<b>SAFETY DATA</b>				
Date tested	19.03.2012	19.03.2011	22.02.2011	08.10.2010
Date of sample taken	19.03.2012	18.08.2011	22.02.2011	28.08.2010
Date of last oil change	-	-	-	-
Top-up since change	1	6000	1500	1500
Opening time since change	h	8718	8520	8278
Total operating hrs	h	8718	-	8278
Oil change	-	-	-	-
<b>WEAR</b>				
Iron	41	42	51	37
Chromium	0	0	0	0
Tin	0	0	0	0
Aluminium	0	0	0	0
Nickel	18	17	15	11
Copper	17	8	13	12
Lead	0	0	0	0
Manganese	2	2	-	-
PQ-Index	OK	28	28	OK
<b>CONTAMINATION</b>				
Sulfur	6	7	10	0
Phosphorus	0	0	0	0
Selenium	0	0	0	0
Vanadium	28	28	33	34
Water K.F.	ppm	6402	1205	1025
W Content	%	negotiable	negotiable	negotiable
Diesel fuel	%	-	-	< 0.30
Biodegrad.	%	0	0	< 0.30
Soot content	%	0.3	0.2	0.1
<b>OIL CONDITION</b>				
Viscosity at 40°C	144.20	125.08	126.84	124.00
Viscosity at 100°C	46	46	46	46
Viscosity index	95	95	95	100
Cloudiness	0	0	0	0
Sulfation	4.48	12	12	10
Elementary	56	61	60	56
<b>ADDITIONALS</b>				
Calcium	533	654	645	501
Magnesium	18	17	18	15
Barium	360	183	183	183
Zinc	312	245	282	271
Phosphorus	228	183	228	223
Barium	0	0	0	0
Molybdenum	0	0	0	0
Sulfur	8	1.26	1.34	1.14
<b>ADDITIONAL TESTS</b>				
BN	mgKOH/g	8.62	9.51	8.41

**Additional sample details**  
 Sample taken by: CIE

**Oil Condition**  
 Viscosity at 40°C: 144.20 mm²/s  
 Viscosity at 100°C: 46 mm²/s  
 Viscosity index: 95  
 Cloudiness: 0

**ADDITIONALS**  
 Calcium: 533 mg/kg  
 Magnesium: 18 mg/kg  
 Barium: 360 mg/kg  
 Zinc: 312 mg/kg  
 Phosphorus: 228 mg/kg  
 Barium: 0 mg/kg  
 Molybdenum: 0 mg/kg  
 Sulfur: 8 mg/kg

**Infra-Red Spectrum**

**Bottle and Cap**

The Independent Marine Oil Laboratory Test Service works with the following test methods for standard engine oils.

Test methods	Result	Unit	Test prescription
Optical Emission Spectroscopy according (OES) ICP/RDE	Wear-, contamination- and additive elements	mg/kg = ppm	DIN 51396-3 ASTM-D 6595
PQ-Index	Index for ferrous magnetic particles	Index	OPV-9-16
FT-Infrared-Spectroscopy	Contamination: Water, Soot, variation to the fresh oil reference	H <sub>2</sub> O and Soot in %	JOAP and reference methods
FT-Infrared-Spectroscopy	Oil Condition: Oxidation, Nitration, Sulfation	A/cm	DIN 51451 DIN 51452
Viscosity	Viscosity at 40°C and 100°C	mm <sup>2</sup> /s	DIN 51562
Viscosity Index (VI)	VI for the viscosity/temperature behaviour	Index	DIN ISO 2909
Visual Inspection	Sample picture	None	OPV 9-12
Sludge Carrying Properties	Ability of dispersants	% (of remaining reserve)	OPV-9-30
Gas Chromatography (GC) for the detection of low boiling compounds	Fuel (MFO)	%	OPV 9-32
Water by KF	Content of water	ppm	DIN ISO 12937
Base Number (BN)	Alkalinity reserve (compared to the fresh oil)	mgKOH/g	ISO 3771
Particle Counting	Cleanliness Code	Number of particle	ISO 4406

Note: Many other tests can be done as needed. The above are typical test methods for engine oils. Hydraulic oil, gear oils and some others may require additional testing, which will be carried out as required.



Source: Oel Check GmbH

## 4. Online Oil Sensors

**While maintenance costs increase and production capacity and equipment performance is optimized the demand for on-line machinery and oil condition monitoring is increasing permanently. CMT had designed a range of instruments to accomplish the primary objectives of oil analysis.**

New technologies deliver new ways to protect your investments. Using our oil sensors to monitor the condition of the oil can now be applied as the technology is available and has proven its worth in the field.

Now more than ever it is necessary to get the most out of the machinery, to minimize downtimes, streamline maintenance and to avoid unnecessary costs.

Online oil sensors are a great addition to your offline oil analysis program giving you an early alert about critical situations. They also might allow to extend the sampling intervals but do give at the same time an indication when an additional oil sample should be sent to a laboratory for more detailed information and double check of the problem.

### Water Monitor



**The effect of water ingress into an oil system can be rapid and catastrophic. The Water Monitor removes the risks associated with periodic off-line testing and potential human error. In comparison to other techniques for water monitoring, CMT's Water Monitor measures the total concentration of water in oil, not just the dissolved water. CMT's Water Monitor already has been installed on a multitude of seafaring vessels, where it proves its worth every single day!**

A robust design with an IP65 housing ensures that CMT's **Water Monitor** can provide permanent, repeatable accurate and reliable real time data in harsh marine and industrial environments.

Continuous on-line monitoring provides the most representative picture of oil condition. Changes are highlighted as they occur and not just at scheduled laboratory analysis. Preventative action can then be taken before a significant damage can occur.

The **Water Monitor** provides accurate feedback of the water concentration in your oil system. With local and optional remote alarms, Water Monitor instantly puts the information enabling the engineers to act accordingly.

In order to enable a long-term record of data, the sensor is equipped with internal data storage unit which can be read out over the serial interface.

#### Specifications

Ambient Temperature:	+5°C to +55°C
Oil Pressure Range:	2 to 10 bar
Maximum Oil Temperature:	< 60°C (at oil inlet)
Power:	110 / 230 V AC 50/60 Hz
Analogue Outputs:	2 x 4 - 20 mA
Connectivity:	USB, RS 232

#### Ordering Information

SEN-CT-16901  
**CMT Water Monitor**

	Specific Oil Calibration	Generic Oil Calibration
Accuracy	+/- 2%	+/- 5%
Resolution	100 ppm	200 ppm

# Combined Oil Condition and Moisture Sensor

The Combined Oil Condition and Moisture Sensor goes beyond the normal protection systems.

CMT's Combined Oil Condition and Moisture Sensor is a real-time, in-line sensing technology for monitoring the health state of lubricating fluids. The device provides continuous insight to oil health, promoting condition-based maintenance practices such as optimized fluid drain intervals and reduced dependence on offline analysis.



Lubricants are used to increase operating efficiency and to maximize life of equipment with relative moving surfaces. While the means by which lubricants perform their function are complex, the main areas for how lubricants lose their functional performance during use can be summarized as:

1. Increased Contaminants
2. Loss of Contaminant Control
3. Loss of Surface Protection

The **Combined Oil Condition and Moisture Sensor** measurement hardware and associated interpretation methods evaluate lubricant health with respect to these degradation modes. The underlying technology for the Sensor is electrochemical impedance spectroscopy (EIS), wherein a dynamic electrical signal is applied to the lubricant and changes in the fluid's electrical response to the signal with time are measured and correlated to chemical and physical changes of the lubricant.



## Specifications

Working Pressure:	150 psi (10.3 bar) max
Ambient Temperature:	-40 to 110°C
Oil Temperature Range:	-40 to 150°C
Storage Temperature:	-40 to 125°C
Viscosity:	Viscosity Independent
Flow Rate:	Flow Rate Independent
Port Type:	-8 SAE J1926-1
Communications:	RS-485 - Modbus RTU, CAN - J1939
Default RS-485 Settings:	115200 baud, 8-bit, no parity, 1 stop bit
Default CAN Settings:	250 kbps
Material:	Nylon 6 / 304 Stainless Steel
Weight:	0.18 kg
Ingress Protection:	IP67
Power Supply:	10-30 Vdc, 100 mA
Output parameters:	Moisture in rh %, impedance

## Key Features:

- CAN-J1939 compatible
- RS485-Modbus RTU compatible
- Multi-frequency analysis
- No moving parts
- Small form factor, easy to install
- Supports all oil types

## Ordering Information

SEN-CT-16903

**Combined Oil Condition and Moisture Sensor**

An EIS measurement of a lubricant typically results in characterization of both the bulk solution and the interfacial reactions. When high frequency interrogation signals are applied to a lubricant system, the response is dominated by polar additives, oxidation by products, and polar contaminants. At low frequencies, the response is dominated by the presence, type, and health of surface-active additives that form films on the electrode surfaces. By measuring both bulk and interfacial properties of a lubricant, EIS offers excellent insight into lubricant health and function.

The **Combined Oil Condition and Moisture Sensor** relative humidity sensing elements use a hydroscopic dielectric compound in a capacitive sensing element to produce an output which correlates with the severity of water contamination. Much like water

is detected in the atmosphere by monitoring relative humidity; relative humidity sensors in oil provide a measure of the dissolved water present. While in the dissolved state, water poses relatively low risk to the system; however, as the level approaches the

oil's saturation point the risk of free water and emulsion formation greatly increases.

For detailed instruction on the use and interpretation of data provided by the oil condition monitor, please contact CM Technologies.

**Your benefits:**

- Optimize oil drain and sampling intervals
- Improve asset health state awareness
- Identify contamination events
- Detect oil changes and top-up events
- Verify proper lubrication system maintenance

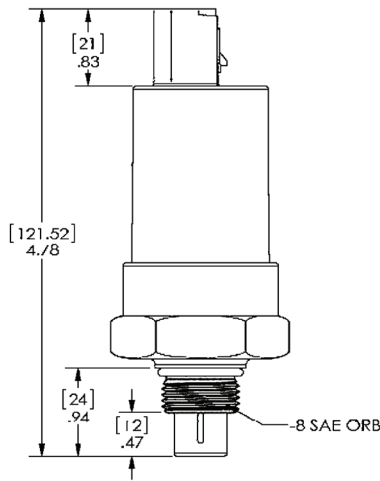

## Oil Sensor Box



Oil Sensor Box

**Consisting of a combination of oil sensors, the Oil Sensor box has been developed to offer real-time monitoring of oil on critical plant such as a wind turbine gearbox. The Sensor Box makes frequent inspections of remote oil and machine health a feasible option. The risk of sampling error is eliminated and data from the sensors can be streamed via any network system, allowing remote monitoring and increasingly effective maintenance planning.**

Designed for mounting into the lubrication system of a machine, the sensor box reports optional metallic particle, oil condition, moisture content of the oil or viscosity. The Sensor Box is part of the CMT Thruster Monitor System.

Individual Oil Sensor Suites are installed local to each thruster measuring the following parameters:

- Metallic Particle
- Oil Condition
- Moisture Sensor
- Oil Temperature
- Flow (yes / no)

Additional parameters are available on request.

Sensor Boxes are being provided including a pump to guarantee effective oil circulation.

**Online Oil Sensors:**

- Ensure good lubricant condition.
- Control contamination.
- Control the wear rate to ensure longer service life.
- Increase the surveillance level of the machine between oil samples.
- Low cost of purchase and ownership.
- Minimal annual servicing costs.
- Minimal installation costs.

**Ordering Information**

CMS-CT-13009  
**Standard Oil Sensor Box**

- Contains:
- Metallic Particle
  - Oil Condition
  - Moisture
  - Flow Control
  - Oil Pump
- (Additional parameters are available on request.)

Sealing: IP 65

# Metallic Particle Sensor

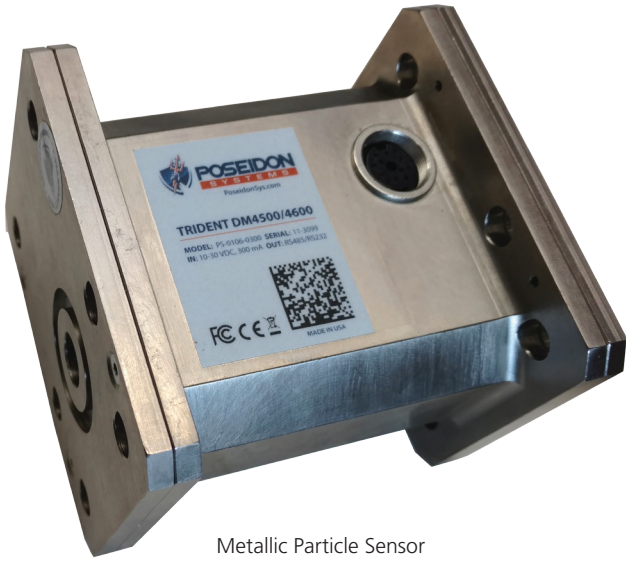

Metallic Particle Sensor

CMT's Metallic Particle Sensor is a real-time, in-line fluid sensing technology for the detection of metallic wear debris and particulates in a lubrication system. By continuously monitoring wear debris generation, the device alerts users to faults in their earliest stages, allowing for lower cost correction actions than conventional schedule based maintenance.

The **Metallic Particle Sensor** will detect, categorize (ferrous vs. non-ferrous), and size metals within a machinery lubrication system. The monitor will detect and measure particles with an estimated spherical diameter of 50 micron ferrous and 150 micron non-ferrous and larger. The compact, robust device can be mounted within just about any lubrication system on any machine.

The sensor communicates in real-time using the MODBUS® serial digital communication standard over RS485 or RS232. This industry standard allows for easy integration into your current systems. But a wide range of output formats are available including particle type/size, approximate mass, and particle counts in user configurable bins.

When connected to a host system the device will give indication of the machinery condition relative to wear metals generated. This gives you the control to improve your asset health

management by being able to make informed maintenance decisions based on real-time data.

## Specifications

Detection Sensitivity (Debris)	40 µm Ferrous & 150 µm Non-Ferrous Metallic Particles
Communications	RS48/RS232 Modbus RTU, Pulse Output
Oil Connection	3/4" -16 SAE Female, -8 JIC Male, -8 BSPP Male, or 1/2" Compression
Ambient Temperature	-40 to 85°C
Fluid Temperature	-40 to 85°C
Volumetric Flow Rate	0.95 - 38 LPM (0.25 - 10 GPM)
Sensor Bore Diameter	(12 mm)
Ingress Protection	IP65
Power Supply	10-30 VDC, 300 mA
Weight	0.68 kg

## Ordering Information

SEN-CT-16904  
**Metallic Particle Sensor**

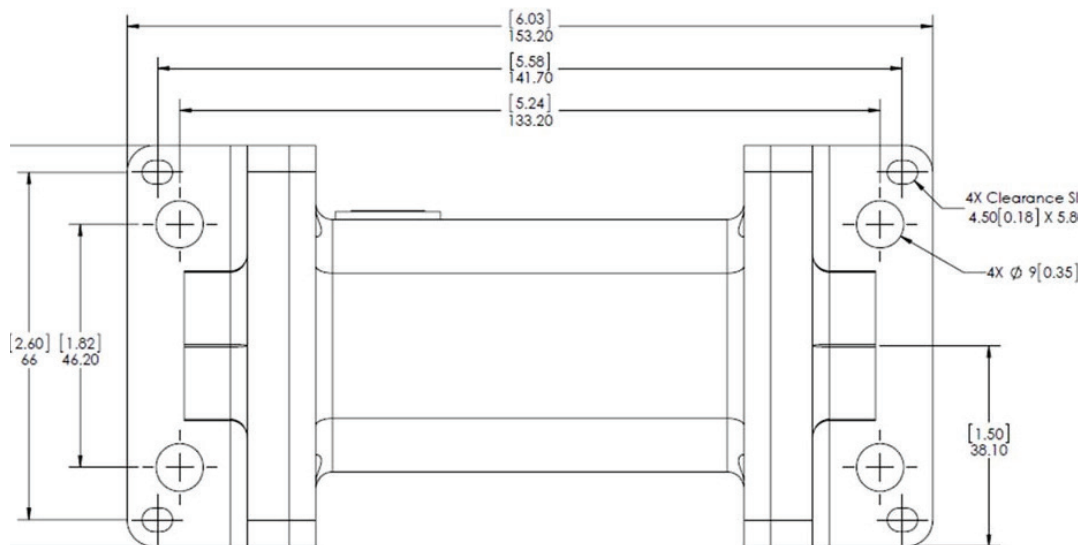

Mounting Pattern of Metallic Particle Sensor

## Density and Viscosity Sensor



Density and Viscosity Sensor

**CMT's Density and Viscosity Sensor is a breakthrough liquid sensing technology that monitors density, viscosity, specific gravity and temperature in real time. Density and Viscosity are very important to ensure an oil film for optimal lubrication on all parts. Lubrication will keep moving metal parts from producing wear and ensure a long lifetime of your engine. The efficiency of your engine can improve with the right viscosity of the fuel.**

The **Density and Viscosity Sensor** is a newly developed sensor with multiple application areas in marine or industrial areas. Testing the viscosity and density is important for diesel or heavy oil to optimise the efficiency of your engine and minimise wear. The compact sensor enables simple installation within the oil cycle. There are different options for installation within the oil cycle. It can be mounted as a bypass (Nessi compatible), a flange within the pipe or even from the tank with a pipe nipple. Alternatively measurements can be simply inserted in the top. All material in contact with the liquid is stainless steel to make the sensor as reliable as possible. The rugged, patented MesoScale® all metal construction provides unrivalled sensitivity, integrity and dynamic response to changes in liquid composition improving the accuracy of the sensor to 0,0045 g/cc in density and 2% on viscosity.

Measurements are being taken in a frequency of 1Hz and can be seen on- or offline on any computer via a standard USB connection (alternatives available).

As sealing the **Density and Viscosity Sensor** uses high quality Viton® (alternatively Kalrez®).

Available mounting options are base plates 1/8", 1/4", 1/2" and 1" NPT (Nessi) or to screw the sensor in the pipe G1/2".

### Specifications

Density Range	650 kg/m <sup>3</sup> - 1350 kg/m <sup>3</sup>
Viscosity Range	0,3 cP - 100 cP
Density Accuracy	0,0045 g/cc
Viscosity Accuracy	2%
Acquisition frequency	1 Hz
Operating Temperature	-40°C - 85°C
Operating Pressure	Atm - 10.0 bar (optional 40 bar)
Communication	RS232 TTL, USB, RS485
Dimensions	38,2 mm x 38,2 mm x 74,6 mm
Weight	320g

### Ordering Information

SEN-CT-16911

**Density and Viscosity Sensor**

#### SCREWED IN PIPE NIPPLE

Used for integration into pipes and tanks

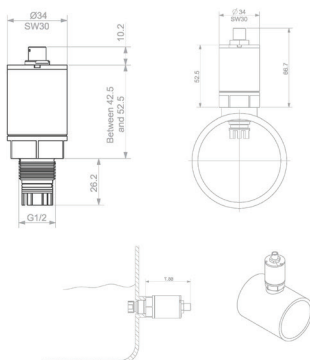

#### FLANGE MOUNTING

Used for integration into pipes, mounting onto tanks

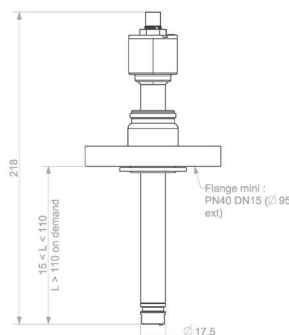

#### SMALL BYPASS APPLICATIONS

Used for integration into lab & process equipments, small lubrication lines, bypass flow out of main pipes

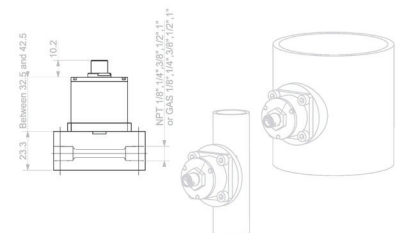

Mounting Options of Density and Viscosity Sensor

## 5. Sampling Solutions

One of the most important aspects of any oil analysis program is the sampling method and the sampling equipment used. The sample needs to be representative for the total amount and uncontaminated. Oil samples are required for regulatory analysis but also for commercial and regulatory purposes.

A representative oil sample will provide an accurate representation of the contaminants, additives, oxidation, particulates and wear condition. If a sample does not represent the real condition of the oil and component at the time of sampling, the reliability of both the test result and its interpretation is in doubt.

Representative fuel oil samples are required for both regulatory and commercial purposes. Crucial aspects of the sampling process include taking the sample, the sampling location and witnessing the process.

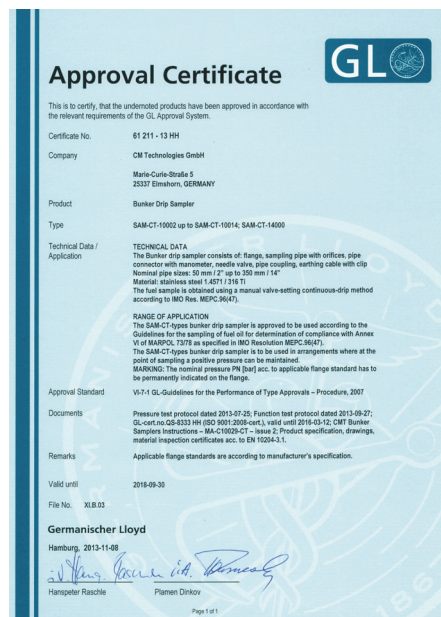

CMT's sampling solutions provide you with everything you need to easily gather an uncontaminated, representative sample of your running liquids.

## Drip Type Bunker Sampler Flange

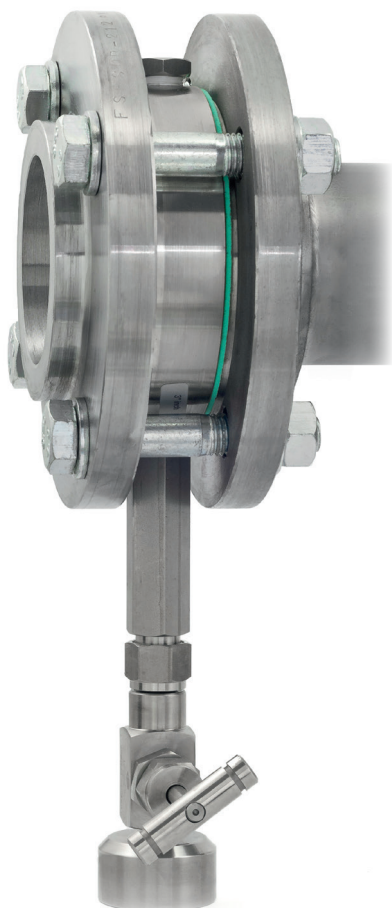

Using a so called drip sampler is the most common and economic way to obtain a representative sample according MARPOL 73/78 Annex VI.

**Our bunker samplers are:**

- Manufactured under strict ISO 9001 quality assurance standards.
- Compliant with IMO MARPOL 73/78 Annex VI helping you to stay within the legal requirements for bunker fuel sampling.
- Weight optimized.
- Simple to install on all common flanges between 2" and 14".
- One size sampler can be used on most common different standard flanges even for different pressure.

**In cases when you have a negative pressure at the point of sampling please use our automatic samplers.**

### Material:

Stainless Steel 1.4571 / 316Ti  
1.4301 / 304  
Flange Thickness: 25/26 mm  
Total Thickness: 31/32 mm

### Selecting the Correct Size of Drip Type Bunker Sampler

Select the nearest size Bunker Sampler with an **outer diameter** smaller than the flanges Pitch Circle Diameter minus the flanges Bolt Hole Diameter.

The **inner diameter** must be larger than the Nominal Pipe Size of the flange.

### Ordering Information

Part Number	Nominal Pipe Size
SAM-CT-10002	50 mm/2"
SAM-CT-10003	75 mm/3"
SAM-CT-10004	100 mm/4"
SAM-CT-10005	125 mm/5"
SAM-CT-10006	150 mm/6"
SAM-CT-10007	175 mm/7"
SAM-CT-10008	200 mm/8"
SAM-CT-10009	225 mm/9"
SAM-CT-10010	250 mm/10"
SAM-CT-10011	275 mm/11"
SAM-CT-10012	300 mm/12"
SAM-CT-10014	350 mm/14"

## Ordering Information Flange (other sizes are available on request) - Material: Stainless Steel 1.4571 / 316T

Part Number	Nominal Pipe Size	Inner Diameter	Outer Diameter	Weight	Flange Standard Correlations
SAM-CT-10002	50 mm/2"	63 mm	95 mm	3.5 kg	JISB2210 5K, 10K, 16K, BS 4504 PN10, PN16, BS10 D, E, F, ANSI B16.5 150, 300
SAM-CT-10003	75 mm/3"	86 mm	127 mm	4.0 kg	JISB2210 5K, 10K, 16K, BS 4504 PN16, BS10 D, E, F, ANSI B16.5 150,300
SAM-CT-10004	100 mm/4"	116 mm	157 mm	4.3 kg	BS 4504 PN16, BS10 D, E, F ANSI B16.5 150, 300
SAM-CT-10005	125 mm/5"	144 mm	188 mm	5.0 kg	JISB2210 5K, 10K, 16K, BS 4504 PN16, BS10 D, E, ANSI B16.5 150
SAM-CT-10006	150 mm/6"	171 mm	216 mm	5.5 kg	JISB2210 5K, 10K, 16K, BS 4504 PN10, PN16, BS10 D, E, F, ANSI B16.5 150, 300
SAM-CT-10007	175 mm/7"	194 mm	241 mm	6.2 kg	JISB2210 5K, 10K
SAM-CT-10008	200 mm/8"	221 mm	266 mm	6.5 kg	JISB2210 5K, 10K, 16K, BS 4504 PN10, PN16, BS10 D, E, F, ANSI B16.5 150
SAM-CT-10009	225mm/9"	260 mm	307 mm	6.7 kg	ANSI B16.5 300
SAM-CT-10010	250mm/10"	281 mm	328 mm	7.1 kg	JISB2210 10K, 16K, BS 4504 PN10, PN16, BS10 D, E, F, ANSI B16.5 150, 300
SAM-CT-10011	275mm/11"	319 mm	361 mm	7.2 kg	JISB2210 10K, BS 4504 PN10, PN16, BS10 d, E
SAM-CT-10012	300mm/12"	340 mm	401 mm	7.5 kg	JISB2210 16K, BS10 F, ANSI B16.5 150, 300, BS 4504 PN10, PN16, BS10 D, E, F
SAM-CT-10014	350mm/14"	375 mm	420 mm	8.0 kg	ANSI B16.5 150,300

## Fuel Sampler

Normally samplers are installed at the ships manifold between the manifold flange and the flange from the bunker hose.

However, sometimes it is more practical to install the sampling device permanently at a different place.

The CMT **Fuel Sampler** is designed to be installed direct into an existing fuel pipe anywhere in the supply line.

It can easily be removed for cleaning. After initial installation the fuel line can be used with or without the sampler being inserted.

### Your benefits:

- Designed specifically for fuel oils
- Easy retrofit
- Service pipes from 2 inch up to 14 inch
- Compliant with ISO 3170

### Ordering Information

SAM-CT-14000

#### Fuel Sampler

Size: 2" - 14"  
50 - 350 mm

Weight: 2.0 kg



## MARPOL Bunker Cabinet



**The CMT MARPOL Bunker Sample Storage Cabinet is a complete unit providing everything needed to comply with the IMO MARPOL regulations. It contains everything for collection, retention and storage of bunker fuel oil samples as required by the IMO MARPOL Annex VI regulations.**

The bunker sample collection and storage is defined in MEPC.96(47). In the guidelines it is defined that a retained sample of all fuel oil as supplied, is drawn at the ships receiving manifold, sealed, signed and then retained under the ship's control until the subject fuel has been substantially consumed, but for at least 12 months from the date of delivery.

### Your benefits

- A robust, fully lockable metal case allows the safe and secure sample storage according to the regulations.
- Everything you need is provided in the same cabinet ensuring compliance with IMO MARPOL 73/78 Annex VI regulations.
- It is supplied with a log book to record your sample details.

Replacement consumables and a full range of drip type or automatic bunker samplers are easily available at short notice on request.

### Ordering Information

SAM-CT-20000

#### **MARPOL Bunker Cabinet**

Content:

- 40 Sample Bottles and Mailer Kit
- 45 MARPOL Fuel Sample Labels
- 45 Clear Adhesive MARPOL Over Labels
- 40 Seals for bottles and sampler
- 24 Cubitainers (5 litre)

## Automatic Fuel Sampler

**Especially bigger vessels are facing the problem of negative pressure at the bunker manifold. Traditional Drip Samplers cannot be used here. They need a positive pressure to allow the sample to flow into the sample container by gravity. The solution is the Automatic Fuel Sampler which does work with vacuum up to -0.8 bar.**

The **Automatic Fuel Sampler** is connected to the main bunker line by a pipe fittings for the permanent installed version.

After start it will automatically sample into the cubitainer and stop after the preset bunker time. The sampler can sample into all size bottles or cubitainers. On special request we can provide a version which can sample into up to 5 individual sample bottles simultaneously or in a sequence. The sampler

can be installed next to the manifold on a wall or right on the manifold.

The standard version works as time proportional sampler ensuring a representative sample. For applications with changing flow rates we also offer a flow proportional version.

Because of ATEX regulations the sampler does not use electricity. All our samplers are pneumatically driven with normal working air between 6 and 8 bar. The samplers can be used under all weather conditions. All fittings are made from stainless steel AISI 316, designed and produced to survive in a harsh environment.



Automatic Fuel Sampler Type 50

The waterproof sampler is equipped with a flushing tank and made of stainless steel. It does have a DNV type approval and complies with MARPOL Annex VI.

The sampler is also available as a wall mounted version

The heavy duty sampler can be installed right on the manifold. It is fully pneumatic driven with bunker timer and does have an automatic stop function. This model is also produced in a low temperature version.

### Ordering Information

SAM-FS-05051

#### Automatic Fuel Sampler Type 50

Size: 350 x 250 x 500 [mm]  
Weight: 15  
Material: AISI 316

#### Compressed Air Pressure

Max. pressure: 12 bar  
Normal pressure: 6-8 bar

#### Fuelline pressure

Standard: -0.4 bar  
Optional: -0.8 bar

Bunker Timer: 1 – 16 hours



Automatic Fuel Sampler Type 70

This very advanced **Automatic Fuel Sampler**, which can sample into 4 bottles simultaneously, is very popular on bunker barges but is also used on merchant ships.

The sampler can sample under all conditions even with very high negative pressure in the bunker line and does give you four most representative samples. This sampler is optional also available for 5 bottles.

The sampler is also available as a vertical wall mounted version.

In addition to the Type 50 specification it does come with a circulating pump to have a heating functionality. It does also have a DNV type approval and complies with MARPOL Annex VI.

### Ordering Information

SAM-FS-07014

#### Automatic Fuel Sampler Type 70

Size: 600 x 600 x 600 [mm]  
Weight: 35  
Material: AISI 316

#### Working Air Pressure

Max. pressure: 12 bar  
Normal pressure: 6-8 bar

#### Fuelline pressure

Standard: -0.4 bar  
Optional: -0.8 bar

Bunker Timer: 1 – 16 hours

**Your benefits:**

- High flexibility and reliability.
- Easy integrated flush system for cleaning purposes.
- Sample container is always filled after bunkering.
- No overflow!
- MARPOL and MEPC.96(47) compliant.
- Time or flow proportional sample.
- No electricity = no ATEX problem.

**Specifications:**

- Size: 350 x 250 x 500 [mm]
- Weight: 15 kg
- Material: AISI 316
- Max pressure: 12 bar
- Min pressure: - 0.4 bar (- 0.8 bar)
- Working air: 6 – 8 bar



## Vacuum Sampling Pump



Vacuum Sampling Pump with 100 ml bottles



Adapter for other bottle sizes

Sampling from tanks, drums and / or engine sumps does create sometimes challenges because the access is difficult. Especially in tanks and drums it is important to not only sample from the top or bottom but to get a representative sample for the total volume.

CMT supplies reliable and easy to use hand operated vacuum sample extraction pumps for simple lube oil sampling.

The vacuum pumps can be used for sample bottles with different necks. The 28 mm sample pump is designed to fit CMT 50 ml sample bottles and the 38 mm plastic pump is designed to fit 100 ml bottle.

Other sizes and special adapters are available on request.

**Sample Extraction Tube (LDPE)** - Clean LDPE tubing to fit sample extraction pump which can be used with most oil systems. Supplied in 15 meter rolls.

**Ordering Information**

SAM-CT-30028

**Vacuum Pump 28 mm Neck**  
(for 50 ml Sample Bottle)

SAM-CT-30038

**Vacuum Pump 38 mm Neck**  
(for 100 ml Sample Bottle)

SAM-CT-30021

**Adapter for 500/1000 ml Sample Bottle**  
Suitable for 38 mm Neck

SAM-CT-30015

**Sample Extraction Tube**  
(about 15 meter)

## Sample Bottles and Cubitainer



1000 ml sample bottles

**CMT produces various different sample bottles for fuel, oils and water.**

**Sample Bottles** - CMT produces a range of **HDPE (translucent)** and **PET (clear)** sample bottles for fuel oil and lubricants.

They are designed to allow oil sampling of warm oils direct from the equipment.

Sample Bottles are supplied in following sizes:

- 50 ml
- 100 ml
- 120 ml
- 1000 ml

Standard bottle neck is 38 mm to fit on the CMT vacuum sampling pump. For all other sizes we provide adapters allowing to sample with the CMT vacuum sampling pump.



50 / 100 / 100 / 120 ml sample bottles.



Cubitainer with caps

**Cubitainers** - fuel samplers use disposable 'cubitainers'. These hold the oil sample before mixing and transfer to the sample bottles and keep out all external contamination.



Cubitainer in a cardboard box

### Ordering Information

SAM-CT-70040

**1000 ml Sample Bottle and Mailer Kit (40)**

Neck: 54 mm

Material: HDPE

SAM-CT-70070

**1000 ml Sample Bottle Pack (70)**

Neck: 54 mm

Material: HDPE

SAM-CT-70250

**120 ml Sample Bottles (250)**

Neck: 38 mm

Material: PETG

SAM-CT-70288

**100 ml Sample Bottles (288)**

Neck: 38 mm

Material: PETG

SAM-CT-70289

**100 ml Sample Bottles (288)**

Neck: 38 mm

Material: HDPE

SAM-CT-70360

**50 ml Sample Bottles (360)**

Neck: 28 mm

Material: HDPE

SAM-CT-70024

**Cubitainers - 5 litre (24)**

Neck: 38 mm

Material: HDPE

SAM-CT-70025

**Cubitainers - 10 litre (24)**

Neck: 38 mm

Material: HDPE

## Sampling Accessories

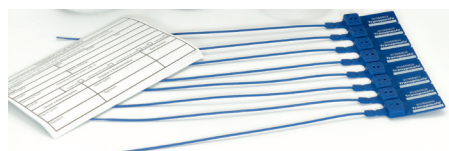

Seals and label



Cubitainer Adapter for DNV Sampler  
Sampler Adapter for DNV Bottles



Seals for bottle shoulder and valve



Mailing box for 1000 ml sample bottles



Plug for Bunker Sampler

**Accessories like mailer kits, labels, adapters and mailing cartons are available for sampling, storage and shipping.**

**Sample Bottle Labels** - CMT does provide self adhesive, pre-printed labels for fuel or lube oil samples. Label for bunker fuel samples are according MARPOL regulations.

**Clear Over Labels** - Clear self adhesive, over labels to protect label and user annotations.

**Bottle Shoulder and Valve Seal** - Some authorities, for example the Port of Singapore, require that the sample flow rate is fixed throughout the bunkering period. The Bottle Shoulder and Valve Seal can be used for securing the valve as well as sealing the bottles for storage.

**Cubitainer Adapter** - The Cubitainer Adapter allow to use CMT Cubitainers on bunker samplers from other manufacturers like DNVPS. Other version to use the CMT drip sampler with customized sampling container are available on request.

**Sampler Gauge** - On bigger vessels the oil often falls several meters down from the ships manifold into the fuel oil storage tank. This can result in unusual pressure conditions. The pressure often becomes negative. A gauge is available for monitoring this to prevent the sample being drawn back into the line.

**Elbow Kits** - For alternative positions CMT does provide a special elbow kit to position the sampler at an angle to the vertical. Elbow kits allow to keep the cubitainer bag hanging vertically.

### Ordering Information

SAM-CT-90001  
**Label for Fuel Sample Marpol Label (180)**

SAM-CT-90002  
**Label for Fuel Sample Marpol Label (990)**

SAM-CT-90003  
**Clear Adhesive Marpol Over Label (990)**

SAM-CT-90004  
**Bottle Shoulder and Valve Seals (100)**

SAM-CT-90006  
**Cubitainer Adapter for DNV Sampler**

SAM-CT-90020  
**Sampler Adapter for DNV Bottles**

SAM-CT-90007  
**Sampler Gauge**

SAM-CT-90008  
**Elbow Kit for 45 degree Elbow**

SAM-CT-90009  
**Elbow Kit for 90 degree Elbow**

SAM-CT-10023  
**Plug for Bunker Sampler**



# Water Condition Monitoring

1. Marine Potable Water Test Kit.....	44
2. Marine Sewage Water Test Kits.....	49
3. Ballast Water Test Kit .....	50
4. Cooling and Boiler Water Test Kits .....	52
5. Marine Automatic Fire Sprinkler System ...	53
6. Produced Foam.....	54
7. Scrubber Caustic Test Kit.....	54
8. Cutting Fluid Test Kit.....	54

## Marine Water Test Kits

Offshore installations and vessels have a variety of systems that require monitoring for either optimal performance, meeting current or forthcoming legislation and to minimize the risks for the crew or visitor's Health and Safety on board.

With these in mind, a new range of CMT Marine Water Kits has been developed to assist and adhere with the above requirements.



The systems that will require monitoring are:

- Potable Water
- Sewage Water
- Boiler & Cooling Water
- Ballast Water
- Fire fighting Foam, sprinkler systems

According to the ever changing legislations CMT is permanently updating the range of Marine Water Test Kits to comply with the current legislations.

### 1. Marine Potable Water Test Kit

Potable water is our most important nutrient and is used for both drinking and cooking. The water being used for personal hygiene and all types of cleaning requires the same high quality. It is therefore important to have enough water of satisfactory quality to cover all types of usage.

International regulations regarding the Potable Water Quality Monitoring and Control were driven by the World Health Organization (WHO) via its International Health Regulations (IHR). And soon enough adapted for on-board potable water, as part of the overall Ship Sanitation Certificate.

MLC 2006 does apply to all seagoing vessels and is in force since the 20th August 2013. Monitoring and control compliance procedures are laid out in the Guide for Ship Sanitation detailing:

- The systems that require monitoring,
- The method and frequency
- The record keeping requirements

Simple regular assessment and testing of the potable water system for microbiological activity, biocide (disinfection control) and implementing a correct control scheme (i.e. temperature monitoring), will ultimately reduce the risk of a disease and save lives.

The CMT **Marine Potable Water Test Kits** were developed to offer rigs and vessels the complete monitoring solutions for their water systems, with additional extras if required.



Potable Water Test Kit

Suitable control schemes with adequate testing & monitoring will aid with the compliance of the current ILO MLC (2006). These test kits provide real time analysis and simple to perform tests which require no specialist training.

According to ILO MLC (2006) also a qualified person is required on board the vessel or rig to perform the test. CMT provides a complete training for **Marine Potable Water Tests** to ensure the attendee is qualified to perform all test according the legislations. At the end of the training each attendee will get a certificate proving the respective qualification.

#### Ordering Information

WTK-CT-80051

##### Standard Potable Water Test Kit

Digital Incubator

UV Lamp

Digital Temperature Meter

Chlorine LR           0 – 1 ppm  
(Free & Total)

Chlorine LR:        0 – 5 ppm

Chlorine HR:        0 – 250 ppm

pH:                    4 pH – 11 pH

Aerobic Bacteria:   0 – 1400 CFU/ml

Coliforms/E Coli:   1 CFU/100 ml

WTK-CT-80052

##### Full Potable Water Test Kit

## The CMT Marine Water Test Solutions comply with:

- MLC (2006)
- WHO Health Regulations (2005)
- ILO 178 (2009)
- European Drinking Water Regulations
- Norwegian Drinking Water Regulations (applies for ALL ships calling Norwegian ports!)



The CMT **Potable Water Test Kit** enables ships staff to monitor the quality of the drinking water on board the ship by providing tests for important operational control parameters and verification tests for bacteria that can be of risk to human health.

The range of tests can be used on the ship either as a standalone control solution or as a supplement to laboratory analysis, dependant on flag state guidelines.

CMT is offering 2 different versions of the **Potable Water Test Kit**. The standard version includes tests for Aerobic Bacteria as well as E Coli. The **Full Potable Water Test Kit** extends the standard test kit with tests for Enterococci and Pseudomonas bacteria.

Both Test Kits include a Digital Incubator to ensure consistent results with same conditions on every test.

### Features:

- Self-contained testing kit for E. Coli and Coliforms.
- Helps you to meet MLC 2006 recommendations for the quality of drinking water.
- Includes compact and robust sample incubator.
- USB with training material.

### Your benefits:

- Incubator ensures that you achieve consistent test results.
- Additional test kits can be added as required to
- Meet flag state and / or company requirements.
- USB training material supports you with crew training and competency.

Same as Standard Test Kit plus:  
 Enterococci: 1 CFU/100 ml  
 Pseudomonas: 1 CFU/100 ml

WTK-CT-80053

### Marine Potable Chlorine Test Kit

Comparator & Cells

Chlorine (Free & Total) VLR: 0 – 1 mg/l  
 Chlorine (Free & Total) LR: 0 – 5 mg/l  
 Chlorine HR: 0 – 250 mg/l

WTK-CT-80054

### Marine Potable Bacteria Test Kit

Digital Incubator

UV Lamp

Digital Temperature Meter

Coliform/E Coli Test: 1 CFU/100 ml  
 Aerobic Bacteria Test: 0 – 1400 CFU/ml

A logbook is included in every Test Kit

**Reagents** (Full refill of respective Test Kit)

WTK-CT-85051

### Standard Potable Water Kit Consumables

WTK-CT-85052

### Full Potable Water Test Kit Consumables

WTK-CT-85053

### Potable Chlorine Test Kit Consumables

WTK-CT-85054

### Potable Bacteria Test Kit Consumables

## Incubator Option

CMT's new portable incubator brings lab like conditions to the field of onsite testing of bacterial contamination.

To create reliable and repeatable incubation conditions when in the field has been a problem in the past because small and portable but on the other hand reliable and temperature stable incubators were not available.

A bacteriological analysis, which is included in many of the CMT Marine Water Test Kits, demands an incubator to create repeatable results.

CMT's **Digital Incubator** offers a reliable, temperature stable environment for the incubation of bacteriological samples and that while being portable and affordable.



Portable Incubator for all Bacterial Test

Applicable for testing of a multitude of different parameters

### Your benefits:

- Portable and therefore usable in the field and in the lab
- Digitally adjustable temperature with real time display of the actual inside temperature
- Clear viewing lid

### Ordering Information

WTK-CT-80020

### Digital Incubator

Capacity: 3.2 l  
 Dimensions: 215 x 161 x 170 mm  
 Operating Temp.: 35°C - 45°C  
 Power: 100 / 240 V AC 50/60 Hz  
 Weight: 4 kg

## Options for Potable Water Test Kits



Turbidity Test Tube



Colour Colorimeter



Chlorine Test Kit

To allow full compliance with international regulations MLC (2006) and ILO 178 including local regulations like the Norwegian Drinking Water Regulations it is essential to do some additional testing not included in the CMT Potable Water Test Kits.

Those tests will be provided with options from CMT. It is also essential to have a proper record keeping which can be done with the CMT log book provided with the manual in the standard kit. International regulations further specify that a trained person needs to be on-board each vessel or rig to perform the tests. CMT does provide different seminars ensuring proper qualification. A certificate will document the respective qualification. You will find our seminar program at the end of this catalogue.

### Colour Colorimeter:

Equip your Water Test Kits with the Handheld **Colorimeter** to measure true Colour more effectively. True colour is caused by dissolved compounds in water and can be natural, artificial or both.

Apparent colour, caused by both dissolved and suspended solids, is measured in Platinum-Cobalt units (PCU). The AWWA (American Water Works Association) recommends < 15 PCU.

CMT's **Colorimeter** makes it easy to measure with only one small device. Not only size is an advantage over chemicals, it is also more accurate.

### Chlorination Option:

The **Chlorination Test Kit** will enable the operator to complete the disinfection process correctly and maintain chlorination levels.

The chlorine HR test is used to check that chlorine has been dosed to the correct levels and the starch/ potassium iodide strips are used to make sure the chlorine has been neutralised. The chlorine LR test is then used to check that chlorine reserves are kept to the maximum permitted level of 0.5 ppm.

The pH test strips are used to check that pH values are between 5 -6 pH during chlorination. The pH should be carefully monitored because acidic pH solutions below 4 can cause the release of chlorine gas which is toxic. When using chlorine as a disinfectant it is important that the pH be 5 - 6 to improve its bacteria reducing properties.

### Ordering Information

WTK-CT-85026

#### Copper Comparator Test

Range: 0 - 1 ppm

Disc & Reagents: 50 tests

WTK-CT-85027

#### Copper Test Strips

Range: 0 - 5 ppm

Strips for: 25 tests

WTK-CT-85028

#### Iron Comparator

Range : 0 - 1 ppm

Reagents: 50 tests

WTK-CT-85029

#### Iron Test Strips

Range: 0 - 5 ppm

Strips for: 25 tests

WTK-CT-85030

#### Turbidity Test

Range: 5-500 JTU

No. of Test: unlimited

WTK-CT-85031

#### Colour Colorimeter

Range: 0-500 PCU

Resolution: 5 PCU

Accuracy: +/- 5%

WTK-CT-85032

#### Colour Colorimeter Standards

WTK-CT-80055

#### Chlorination Test Kit

Base Equipment

Chlorine HR Test: 0 - 250

Chlorine LR Test: 0 - 1 ppm

pH Test Strips: 0 - 14 pH

Starch/Potassium Iodide Test Strips



Legionella Test Strip



Legionella Industrial Kit



pH / Temp Meter



Conductivity / TDS Meter

## Legionella Option

Legionella is a bacteria which can cause a pneumonia-like disease called "Legionnaires' Disease". Infection occurs when the bacteria is inhaled from aerosols of contaminated water. Aerosols can be produced anywhere water is splashed or sprayed but some of the most common sources associated with Legionnaires' Disease are showers.

The **Legionella Industrial Test Kit** is a breakthrough technology from CMT for the rapid detection of Legionella bacteria in marine potable water systems—delivering test results in minutes instead of days. The test kit contains everything required to perform 5 tests – including sample collection containers and disposable pipettes.

- Optimised for use with hot and cold water systems on-board ships.
- Simple to use and fast, with no interpretation required.
- Results are easy to read and obtained within 25 minutes.
- No chemicals.
- Immediate understanding and response to the water conditions.
- Reduce risk of outbreaks and litigation.
- Increase confidence in your Legionella control.

## Conductivity Option:

Conductivity is an indirect measurement of total dissolved solids. Typical value (approximately) for untreated distillates is 50  $\mu\text{S}/\text{cm}$ . Water from shore sources should have around 500  $\mu\text{S}/\text{cm}$ . Seawater has about 50,000  $\mu\text{S}/\text{cm}$ . Therefore a high conductivity could be an indication for seawater ingress. A too low conductivity value should trigger evaluation of corrosive processes in the piping and existing of heavy metals due to corrosion.

## pH Option:

Ideal pH value depends on the materials used. A pH value above 8 does not allow effective water disinfection with chlorine and gives evidence that self produced water may not be re-mineralized adequately. Further assessment of water quality should be performed.

## Ordering Information

WTK-CT-80010

### CMT Legionella Industrial Kit (5)

(Distribution System)

Detection Limit:	100 CFU/L
Operator Time:	< 2 minutes
Development Time:	< 35 minutes

WTK-CT-80040

### CMT Legionella Biofilm Test Kit (5)

(Biofilm Cold Water Storage Tank)

Detection Limit:	200 CFU/ swapped area
Operator Time:	< 2 minutes
Development Time:	< 35 minutes

WTK-CT-85012

### Conductivity / TDS Meter

Range:	0 – 2000 $\mu\text{S}$ ; 2 – 20 mS; 0 – 13000 ppm
Accuracy:	+/- 2%
Test time:	< 1 minutes
Reagents:	non hazardous
Calibration Pack:	WTK-CT-85005

WTK-CT-85013

### pH Meter

Range:	
pH:	-2 – 16
Temp:	0 – 90°C
Accuracy:	+/- 0.02 pH / 0.3°C
Test time:	< 1 minutes
Reagents:	non hazardous
Buffer Solution 4.0:	WTK-CT-85014
Buffer Solution 7.0:	WTK-CT-85015
Buffer Solution 10.0:	WTK-CT-85016

## Silver Copper Ionisation Test Kits



Silver Test

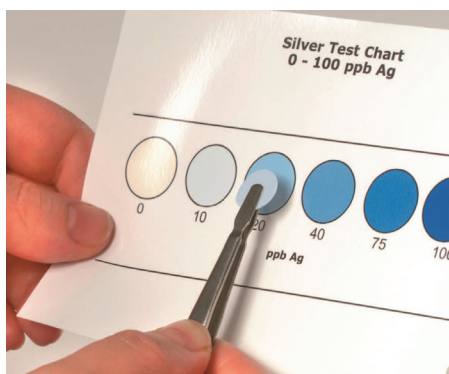

Colour comparison on Silver Test



Copper HR Colorimeter



Silver Iron Photometer

### Silver Copper Ionisation Test Kits

Water treatment systems that electrolytically generate copper and silver ions for the control of bacteria (including planktonic Legionella) in hot and cold water systems are becoming more and more common. Silver concentration should be a minimum of 20 ppb and higher with hard water feed.

It is important that installers of ionisation systems take into consideration regulations on maximum allowable copper and silver levels (The Water Supply (Water Quality) Regulations), as well as local water quality.

Hardness and pH are two important factors that can affect the efficiency of the whole process. Copper ions are also required to complete the synergy.

To perform an analysis, simply add a reagent sachet to 50 ml of sample water; filter this through a small membrane and compare the colour of the membrane with the standard colour chart.

The test takes just a few minutes to complete, ensuring correct operating conditions. Ideal for checking sentinel outlets on a monthly basis and representative taps on a rotational basis.

### Copper HR Colorimeter

The **Copper HR Colorimeter** is a simple, accurate and cost effective way to measure high ranges of copper.

Designed as a more accurate alternative to chemical tests, the Colorimeter provides quick, accurate results in four easy steps.

The Colorimeter uses an adaptation of the EPA method. The reaction between copper and the reagent causes a purple tint in the sample.

### Silver Iron Photometer

The **Silver Ion Photometer** is a small, lightweight digital photometer, specifically designed to accurately measure silver ions in water.

The Photometer features an advanced optical system; the combination of a special 570 nm LED lamp, a narrow band interference filter, and silicon photocell ensuring accurate photometric readings every time.

### Ordering Information

WTK-CT-80006

#### Silver (Free) Ionisation Test Kit

Range: 10 - 100 ppb  
No. of tests: 100

WTK-CT-85023

#### Silver Ion Photometer

Range: 0.0 - 0.2 ppm  
(0-200 ppb)  
Resolution: 0.01 ppm  
Accuracy: +/- 2%

WTK-CT-80050

#### Copper Comparator Test Kit 0-1 ppm

Range: 0-1 ppm  
No. of tests: 100

WTK-CT-80049

#### Copper LR Colorimeter 0-5 ppm

Range: 0-5 ppm  
Resolution: 0.01 ppm  
Accuracy: +/- 5%

WTK-CT-85021

#### Silver (Free) Ionisation Consumables Pack

No. of tests: 100

WTK-CT-85024

#### Silver Ion Photometer Calibration Kit

WTK-CT-85025

#### Silver Ion Photometer Reagent Kit

No. of tests: 100

It is currently the easiest to use, quickest and most accurate silver ion measurement tool on the market. Using the highly accurate span calibration method for faster more accurate results than conventional silver ion meters.

## 2. Marine Sewage Water Test Kits

**MARPOL Annex IV contains a set of regulations regarding the discharge of sewage into the sea from ships, including regulations regarding the ships' equipment and systems for the control of sewage discharge, the provision of port reception facilities for sewage, and requirements for survey and certification (ISPPC – International Sewage Pollution Prevention Certificate).**

The discharge of raw sewage into the sea can create a health hazard, while in coastal areas sewage can also lead to oxygen depletion and an obvious visual pollution.

Environmental issues are still a hot topic these days. The shipping community expresses its concern about the ecosystem and the pollution of the seas. In this market where low freight rates, new rules and regulations and a higher customer demand are pressuring our business-results, we still desire to comply with new rules and regulations but preferably in a cost-effective and efficient way

To test the discharge of Sewage treatment plants CMT offers a quick and easy drop test for testing the free chlorine content.



As set out in Annex 22 Resolution MEPC.227(64) adopted on the 5th October 2012, sewage treatment plants installed prior to 1st January 2010, on ships other than passenger ships operating in MARPOL Annex IV special areas and intending to discharge treated effluent into the sea, should comply with resolution MEPC.2(VI) adopted on 3rd December 1976.

ISPPC (International Sewage Pollution Prevention Certificate) are issued upon successful inspection and are valid for 5 years.

For renewal and random inspections, maintaining the system operating requirements in line with the effluent standards will be required. With this in mind, the CMT Marine Sewage Effluent Test Kit will provide simple and accurate testing.

Requirements from MARPOL Annex IV Resolution MEPC.159(55) – Effluent & Performance Standards are defined as follows:

- BOD up to 25 ppm
- COD up to 125 ppm
- Total Suspended Solids max. 35 ppm
- Coliforms up to 100 CFU / 100 ml
- pH 6.0 – 8.5
- Chlorine (Free) up to 0.5 ppm

Nowadays tests in the market are complicated and comprehensively. The Chief-Engineers almost need to have a chemist-degree in order to understand and execute the time consuming tests. The CMT Sewage Effluent Test Kits are simple and very user-friendly.

The **Budget Sewage Effluent Kit** provides an indication for the key parameters set out in MARPOL Annex IV. The coliform dip slides provided will require an incubator to ensure accuracy, which can be purchased separately. For complete accuracy you will need to purchase the standard range of sewage effluent kits. These come complete with a coliform plate method and incubator. The coliform plate method provides a MPN count, which will provide more accuracy than the coliform dip slides.

Regular testing will allow rapid corrective action to take place if required, helping to maintain optimum operating conditions, minimum downtime and reducing costs. Ultimately the CMT Marine Effluent Cabinet will aid compliance with MARPOL Annex IV.

### The CMT Marine Water Test Solutions comply with:

- MARPOL Annex IV: Resolution
  - MEPC.2 (IV)
  - MEPC.115 (51)
  - MEPC.159 (55)

### Ordering Information

WTK-CT-80041

#### **Sewage Effluent Test Kit 1 Complies with MEPC 2(VI) Commission before 2010**

Coliform Bact. (12): 0 – 2424 CFU/100ml  
TSS (unlimited): 5 – 500 mg/l  
BOD (unlimited): 7.5 – 255 mg/l O<sub>2</sub>  
Thermometer: -50 to 150°C  
Digital Incubator 25 - 45°C

WTK-CT-80042

#### **Sewage Effluent Test Kit 2 Complies with MEPC 159(55) Commission 2010 and later**

Additionally to WTK-CT-80041:  
COD Test (25): 0 – 300 mg/l  
pH Test Strips (50): 4 – 10 pH  
Free Chlorine (100): 0 – 1.0 ppm  
Free Chlorine (100): 0 – 30 ppm

WTK-CT-80043

#### **Sewage Effluent Test Kit 3 Complies with MEPC 159(55) & 227(64) All Passenger Ships**

Additionally to WTK-CT-80041:  
COD Test (25): 0 – 1500 ppm  
pH Test Strips (50): 5 – 11 pH  
Free Chlorine (100): 0 – 1.0 ppm  
Free Chlorine (100): 0 – 30 ppm  
Total Nitrogen (25): 0.5 - 25 ppm  
Total Phosphorus(25): 2 - 2.6 ppm

WTK-CT-80044

#### **Budget Sewage Effluent Test Kit**

Dip Slides (10) 0 - 100,000 CFU / ml  
TSS (unlimited): 5 – 500 mg/l  
BOD (unlimited): 7.5 – 255 mg/l O<sub>2</sub>  
COD (100): 0 - 300 mg/l  
pH Test Strips (50): 5 – 11 pH  
Free Chlorine (100): 0 – 1.0 ppm  
Free Chlorine (100): 0 – 30 ppm  
Thermometer: -50 to 150°C

#### **Reagents** (Full refill of respective Test Kit)

WTK-CT-85041

#### **Sewage Effluent Consumables Pack 1**

WTK-CT-85042

#### **Sewage Effluent Consumables Pack 2**

WTK-CT-85043

#### **Sewage Effluent Consumables Pack 3**

WTK-CT-85044

#### **Sewage Effluent Consumables Pack Budget**

### 3. Ballast Water Test Kit

**As everyone in the industry knows, ballast water exchange is an important process, but it's one which involves several complex processes. There are guidelines which need to be followed in order to ensure the water is as safe and hygienic as it can possibly be.**

The presence of any harmful bacteria, viruses and invasive species on a ship can have catastrophic effects, so our highly developed ballast water test kits are vital. Easy to use and reliably accurate, the kit enables user companies to remain compliant with current and future legislation and guidelines.

Exchanging ballast water in a timely, efficient and safe manner is an important aspect of modern marine life, but it should always be monitored effectively. With CMT on your side, you can be sure that your vessels and offshore installations are operating properly.

A successful inspection will valid a 5 year certificate for the system. For a renewal or random inspections the ballast water system should be in line with the IMO Ballast Water Convention (2004).

The IMO Ballast Water Convention (2004) specifies three different standards:

1) The **Ballast Water Exchange Standard** specifies the exchange of ballast water at sea. Ships performing ballast-water exchange shall do so

with an efficiency of 95% volumetric exchange of ballast water.

The exchange procedure shall be carried out in an 'open ocean condition' at least 200 nautical miles from the nearest land and in waters at least 200 meters in depth. This can be monitored with each of the CMT Ballast Water Test Kit.

2) The **Ballast Water Performance Standard** cares about the performance of the system and specifies the maximum number of viable organism in the ballast water.

50 µm or above – less than 10 living organisms per cubic metre (1000 litres).

10 µm – 50 µm – less than 10 living organisms per millilitre.

3) The **Ballast Water Health Standard** defines limits for indicators which could cause health problems. It specifies the maximum number of Cholerae, E. coli and Enterococci bacteria as well as the total viable count of any bacteria in the ballast water.

Total Bacteria less than 1000 CFU/100 ml

E. coli less than 250 CFU/100 ml

Enterococci less than 100 CFU/100 ml

Vibrio Cholera (O1 & O139) Zero/100 ml

Ships are required to have an **Ballast Water Management Plan** and a **Ballast Water Record Book**. The Ballast Water Record Book is essential to prove compliance with the three Ballast Water Standards.



#### Ordering Information

WTK-CT-80033

##### Ballast Water Test Kit I

(VGP 2013 US Coastguard BWTS Requirements)

Total Bacteria (10): 0 – 1400 CFU

E-Coli Test (10): 0 – 2424 CFU

Enterococci Test (10): 0 – 115 CFU

Vibrio Cholera: yes/no (O1 & O139)

Incubator: 110 / 240 V

UV Lamp

WTK-CT-80034

##### Ballast Water Test Kit II

additionally to WTK-CT-80033:

Salinity Refractometer (salt in seawater)

Zooplankton Filter Test (50) (10 µm)

Zooplankton Filter Test (50) (50 µm)

WTK-CT-80035

##### Ballast Water Test Kit III

additionally to WTK-CT-80033:

Salinity Refractometer (salt in seawater)

Digital handheld Fluorometer for

Zooplankton

**Reagents** (Full refill of respective Test Kit)

WTK-CT-80048

##### Ballast Water Consumables Pack 1

WTK-CT-80046

##### Ballast Water Consumables Pack 2

WTK-CT-80047

##### Ballast Water Consumables Pack 3

#### Options for residual Biocide Monitoring

WTK-CT-85045

##### Chlorine Dioxide Comparator (20)

Range: 0 - 6.65 ppm

WTK-CT-85046

##### Chlorine Comparator Test (20)

Range: 0 - 1.0 ppm

WTK-CT-80036

##### Ozone Comparator Test (20)

Range: 0 - 3.4 ppm

WTK-CT-80037

##### Peracetic Acid Drop Test (20)

Range: 0 - 20 ppm

WTK-CT-80038

##### Hydrogen Peroxide Comp. Test (20)

Range: 0 - 50 ppm

The CMT test Kits meet the rules of the US Coastguard requirements (VPG 2013), according to which a large number of flag states handle the ballast water treatment.

This includes among others:

### 1) Ballast Water System Functionality Monitoring.

Ballast water treatment systems use physical and/or chemical processes to achieve reductions in living organisms (i.e. filters, chlorine dioxide, cavitation, UV & hypochlorite). To assess the BWTS functionality, monitoring of the BWTS functionality is required at **least once per month** for specific parameters that are applicable to your system.

### 2) Effluent Biological Organism Monitoring

This must be conducted **6 times during the first year** the system is installed or used. If the sampling results are within the below parameters for two consecutive events, the vessel may **reduce monitoring to 1 time per year** after the first year.

#### Parameters & Limits

Total Bacteria less than 1000 CFU/100 ml  
E. coli less than 250 CFU/100 ml  
Enterococci less than 100 CFU/100 ml

### 3) Residual Biocide Monitoring

You must conduct monitoring of the vessel ballast water discharge for any residual biocide used in the treatment process. Initial monitoring is 3 times in the first 10 discharge events (not exceeding a 180 day period), thereafter under maintenance monitoring 2 times per year.

#### Parameters & Limits

Chlorine Dioxide: max.. 0.2 ppm  
Chlorine: max. 0.1 ppm  
Ozone: maximum 0.1 ppm  
Peracetic Acid: max. 0.5 ppm  
Hydrogen Peroxide: max. 1 ppm

Exchanging ballast water in a timely, efficient and safe manner is an important aspect of modern marine life, but it should always be monitored effectively.

CMT is offering 3 different Ballast Water Test Kits to suit your needs.

## Rapid Ballast Water Test Kit

The CMT Rapid Ballast Water Validation Test Kit provides a simple rapid method for determining the efficiency of ballast water treatment systems.

Our validation kit provides ship operators, Port State Control (PSC), and other compliance officers with a simple, effective tool to assess the risk of discharging ballast water.

#### Complete Solution for Regulatory Compliance

The 2004 BWM Convention guidelines include recommendations on methodologies for sampling and analysis to test for compliance with the convention.

Utilizing three instruments, the CMT **Rapid Ballast Water Test Kit** satisfies the testing protocol for the D1 standard, allows a user to quickly and easily decide

if a system is in gross exceedance of the D2 standard, and provides a simple solution to test total residual oxidant levels in chemical disinfection systems.

A salinity refractometer provides a simple test to confirm that an exchange occurred.

A portable, pocket size digital fluorometer tests for photosynthetically active chlorophyll, like that found in living phytoplankton, in less than 3 minutes. This will provide an indication of whether or not the treatment of the ballast water system was effective .

A waterproof colorimeter tests for Total Residual Oxidant (TRO) with a range of 0 to 5 ppm free & total chlorine in less than 3 minutes.

The handheld fluorometer requires no training prior to use - simply place the sample in the cuvette, press "Read" and

view the risk of discharge (Fail, High, Low).

Ship operators can easily verify whether the ballast water treatment system has adequately treated water prior to discharge.

Compliance officers can quickly determine whether a ship exceeds D2 standards. In case of positive results further in-depth laboratory analysis can then be performed.

Ballast water treatment system providers rapidly assess treatment system performance during testing.

Ship service providers - diagnose treatment system failures

#### Ordering Information

WTK-CT-80045

#### Rapid Ballast Water Test Kit

Salinity Refractometer (salt in seawater)

Scale Range: 0 - 100 ppt

Accuracy: +/- 1 ppt

Digital handheld Fluorometer

Dynamic Range: 3 orders of magn.

Resolution: 12 bits

Chlorine Colorimeter

Range: 0 - 5.00 mg/l

Resolution: 0.01 mg/l

Accuracy: +/- 0.03



## 4. SHIPSAFE® Cooling and Boiler Water Test Kits

Engine cooling systems contain carefully blended additives that prevent scale deposits and corrosion of engine waterways. It is very important that the concentration of the additives is maintained at the correct level for optimum protection.

Every industry that operates boiler and cooling water systems – ranging from power plants, vessels or other industrial plants – needs to regularly test the water to analyze a number of parameters. This is imperative as it avoids corrosion and malfunction. CMT offers the ideal solution for all specific requirements.

CMT is dedicated to providing our customers with the most convenient, reliable and secure systems for all analyses purposes. To specifically serve all industries that employ or deal with water testing.

CMT supply treatment test kits for engine cooling water and steam boiler water.

The kits are very simple to operate and will enable the ships engineer to monitor scale and corrosion inhibitor concentrations. Regular testing will allow rapid corrective action to take place helping you to maintain optimum operating conditions, minimise down-time and reduce energy costs.

Low and medium pressure steam boilers are treated with special corrosion and scale inhibitors.

It is vitally important to maintain precise levels of these additives to ensure correct and efficient steam generation. Failure to regularly maintain and monitor treatments will inevitable end in system failure and expensive corrective maintenance.

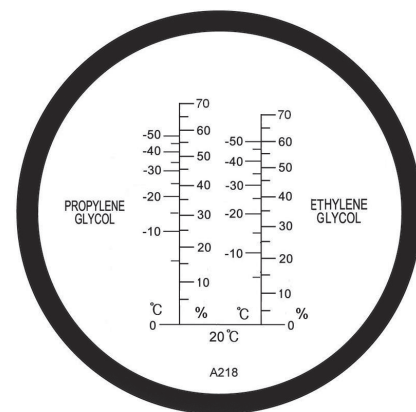

### Ordering Information

WTK-CT-80015

#### Cooling Water Test Kit

Chloride	20 - 12000 ppm
Nitrite	10 - 2000 ppm
pH Test Strips	4,5 - 10 pH
No. of tests:	100

WTK-CT-80058

#### Marine Boiler Water Kit

Chloride	20 - 12000 ppm
P-Alkalinity	0 - 2400 ppm
pH Test Strips	7-14 pH
No. of tests:	100

WTK-CT-80059

#### Marine Boiler & Cooling Water Kit

Combines WTK-CT-80058 & -80015	
No. of tests:	100

WTK-CT-80065

#### CMT Total Hardness LR & HR Drop Test

Range:	(0-1200 ppm)
--------	--------------

WTK-CT-80064

#### Glyscorr Chloride Test

Range:	(50-300 ppm)
--------	--------------

WTK-CT-80017

#### Glycol Refractometer

Range:	0-70%
--------	-------

WTK-BW-80026

#### BRIX Refractometer

Range:	0-10 BRIX
--------	-----------

WTK-CT-85013

#### pH Meter

Range:	pH: -2 - 16	Temp: 0 - 90°C
Accuracy:	+/- 0.02 pH / 0.3°C	
Test time:	< 1 min	
Reagents:	non hazardous	
Buffer Solution 4.0:	WTK-CT-85014	
Buffer Solution 7.0:	WTK-CT-85015	
Buffer Solution 10.0:	WTK-CT-85016	



To measure Chloride in cooling water treated with the corrosion inhibitor Glyscorr G-93/94 the standard Chloride test, also from other suppliers, will not work. To specifically serve our customers using Glyscorr G-93/94 as additive, the new **Glyscorr Chloride Test Kit** has been developed.

To measure the level of Glycol in cooling water CMT also provides a **Glycol Refractometer**. The refractometer allows easy tests of the level for Propylene and Ethylene Glycol up to 70% securing a protection down to -50°C.

### Your benefits:

- Optimise operating conditions
- Reduce energy costs
- Measure key boiler and cooling water inhibitors
- Simple step-by-step instructions



pH / Temp Meter

Conductivity / TDS Meter

## Tablet Count Boiler and Cooling Water Test Kit Options

**Alternatively to the Drop Tests CMT is also offering tablets tests for boiling and cooling water.**

Tablet count methods have been historically used in the marine industry. The tablet count process forces the sample water to change colour based on the number of tablets added. The value can then be determined on a

conversion table based on the number of tablets it takes for the colour to change.

Tablet count methods are classed as hazardous for shipping and less accurate than the recently developed drop test methods. For non-hazardous options please refer to the SHIPSAFE® range of boiler and cooling water test kits.



### Ordering Information

WTK-CT-80060

#### 310 Boiler Water Kit

Alkalinity (P) Tablets 250 pc.  
Chloride Tablets 250 pc.  
pH Test Strips 7-14 100 pc.

WTK-CT-80061

#### 309 Cooling Water Kit

Chloride Tablets 250 pc.  
Nitrite No 1 Tablets 100 pc.  
Nitrite No 2 Tablets 250 pc.  
pH Test Strips 4-10 100 pc.

WTK-CT-80062

#### 313 DEHA Kit

DEHA Test Solution 1 65 ml  
DEHA Test Solution 2 30 ml  
Comparator Unit

WTK-CT-80063

#### 312 Hydrazine Kit

Hydrazine Test Powder 40 g  
Comparator Unit

## 5. Marine Automatic Fire Sprinkler System Test Kit

**The reliability of an automatic fire sprinkler is very important. To prevent malfunction during an emergency the water inside of the system needs to be monitored to control corrosion and other hazards.**

The IMO has issued revised guidelines (contained in circular MSC.1/CIRC.1516) for in-service testing of automatic sprinkler and automatic mist systems.

The amended guidelines advise shipowners, operators and system manufacturers to actively monitor and assess the effectiveness of automatic sprinkler and automatic mist systems on a planned periodical basis. Water quality testing should be performed on a quarterly basis and results recorded.

Corrosion can cause major catastrophic problems with these systems, potentially causing system failure and leakage (pin-hole size leaks). We have included within the test kit testing for pH, conductivity



and testing microbiological levels (total count of bacteria & sulphate producing bacteria).

Salt water ingress normally occurs when the system has been used (fresh water) and once depleted is normally by-passed directly using sea water. If this occurs the system is flushed through with fresh water. A chloride test is provided to ensure the sea water is not present which can cause corrosion problems.

Any part of the system may be subjected to freezing temperatures in service. Anti-freeze (mono-ethylene & mono-propylene glycol) is used as standard to protect these systems from freezing. A glycol refractometer is supplied to ensure the systems are being maintained at the correct freeze point or percentage product.

### Ordering Information

WTK-CT-80057

#### Marine Automatic Fire Sprinkler System Test Kit

pH Stick Meter  
Conductivity Meter  
BT2 Dip Slides (10)  
SRB Dip Slides (10)  
BC1 Potassium Chromate Indicator (65 ml)  
BC2 Chloride HR Titrant (65 ml)  
Glycol Refractometer  
250 ml Wide Neck HD Bottle

## 6. Produced Foam Test Kit

The CMT Produced Foam Test Kit has been designed for the validation, testing and calibration of produced fire fighting foam induction systems.

It offers fire safety professionals real time analysis so that the systems being tested are managed and calibrated correctly.

### Application and Use

It is suitable for testing to the following International Produced Foam Test Standards:

NFPA 11 2002 (paragraphs 10.6.2 and 3) BS5306



It is also suitable for use with AFFF, Protein and AR Foams.

Fire fighting foam induction systems require regular performance testing and often as a result recalibration.

The **Produced Foam Test Kit** enables systems to be easily calibrated, without the need to send samples

### Ordering Information

WTK-CT-80029

**Produced Foam Test Kit**

## 7. Scrubber Caustic

**Both IMO and EU policies require ship operators to reduce the sulphur emissions of their ship operations. Vessels operating in a Sulphur Emission Control Area (SECA) need to use either low sulphur distillate fuels or have an approved exhaust gas treatment system installed onboard to capture sulphur emissions.**

When vessels are operating in SECAs, closed loop scrubbing is required. In order to maintain alkaline levels in the scrubbing water, and as either fresh or sea water pH range can be 6.5 - 8.5, for the effective scrubbing sodium hydroxide (NaOH) in a 50% solution is commonly used.

This kit has been developed to simply and quickly allow the crew to sample

and analyse the caustic soda during bunkering in order to validate the % solution supplied matches the supply specification and if not to adjust system dosing accordingly or reject delivery.

### Ordering Information

WTK-CT-80066

**Scrubber Caustic Test Kit**

Range 1-50 %

## 8. CMT Cutting Fluid Test Kit

**Cutting fluids are required in metal machining to improve tool life, reduce work piece thermal deformation, enhance surface finish and to flush chips from the cutting zone. These fluids degrade with time due to bacterial growth and contamination with tramp oil. Testing is not just essential, its required!**

Health risks exist for lathe operators by both fluid contact (dermatitis) and breathing of the mist / vapour (asthma, extrinsic allergic alveolitis and other breathing problems). Biocidal additives improve the life of the fluid and reduce the hazard to health.

The **Cutting Fluid Test Kits** measure the key parameters necessary to optimise cutting fluid performance and enable enumeration and safe control of microbiological contamination.

The basic kit is supplied with tests for cutting fluid concentration, pH, & water hardness.

### Your benefits:

- Compact and portable
- Designed for compliance with Health and Safety legislation
- Simple step-by-step instructions
- Rapid results
- Safely controls microbiological contamination.



A deluxe version, incorporating a dip slide incubator is also available for accurate trend analysis over a number of months.

### Ordering Information

WTK-CT-80039

**Basic Cutting Fluid Test Kit**

RBS Dual Dip Slides 10

(TVC & Yeasts/Moulds)

pH Meter 1

Hardness Test Strips 50

Nitrite/Nitrate Test Strips 50

Brix Refractometer 1

WTK-CT-80056

**Deluxe Cutting Fluid Test Kit**

Same as Basic Test Kit

Dipslide Incubator 1

# Vibration Monitoring

1. Vibration Meter .....	56
2. Vibration Analyser.....	61
3. Vibration Monitor .....	67
4. Software.....	70
5. Spares and Accessories .....	72

## 1. Vibration Meter

**Bearing problems are the most common cause for machine and plant damage. Slight misalignment or imbalance creates significant greater than expected load for a bearing.**

**Very often bearing lubrication is found insufficient. All of these factors reduce the service life of bearings. The identification of insufficient lubrication or a source for a bearing damage is no great matter and done in a few minutes.**

A detailed problem analysis is important. So it happens that engineers suspect a bearing damage, but gear problems are actually present. The bearings are replaced now, costs are incurred without eliminating the problem. Therefore it is essential to find the cause of the problem.

Just changing a bearing where an imbalance or a misalignment is causing the problem does not solve the problem and the bearing will fail shortly again creating more cost.

Statistics show that insufficient bearing lubrication is the highest cause for most bearing damages. Finding lubrication problems is simple and fast with the CMT vibration and devices. A single measurement of only a few seconds gives information about the lubrication of the bearing. Avoid bearing damage and unnecessary costs without much effort.

### What is vibration diagnostics?

Vibration diagnostics is a major part of predictive machine maintenance programs. Vibration diagnostics has over the years proven to be the most effective method for checking "machinery health".

Vibration diagnostics tools are here to help us to predict the machine failures. When predictive maintenance is applied and the machines are checked regularly, machine faults can be discovered at an early stage and appropriate action can be taken. By doing so you can avoid

unexpected machine shutdowns and you can prevent replacement of parts which are still in good condition.

CMT supplies a full range of vibration diagnostics equipment, from simple data collectors to advanced vibration analyzers and on-line monitoring systems. The data from the devices can be transferred to Adash software for further analysis.

### How does it work?

Running machines generate vibrations, which contain a lot of information about their condition. A vibration meter or analyzer is used to measure this vibration. The sensor needs to be mounted on an appropriate point on the machine (e.g. bearing housing). The instrument measures the vibration signal, tells you the severity of the vibrations and also possible machine faults. The most frequent faults are bearings faults, unbalance, misalignment and looseness.

## Vibration Meter Marine

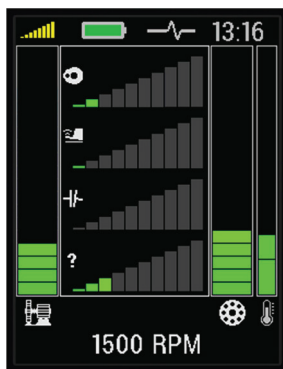

**CM Technologies GmbH complements its range of easy to use monitoring tools with the new Vibration Meter Marine.**

**CMT's goal is to provide the right solution for the job at hand and is proud to present the new version of their Vibration Meter specifically made for the Marine industry.**

Crews of seagoing vessels are under constant stress and the crew changes in fixed intervals. Therefore to successfully use a Vibration Monitoring device onboard it must be easy and intuitive to use. It needs to offer measurement results which the crew can immediately understand and which help the crew with their task of maintaining the vessels machinery. The **Vibration Meter Marine** offers measuring modes exclusively for the Marine industry.

A powerful Expert system provides on the spot usable results without the need to send the information on shore for evaluation, even beginners can use these results right away without any training or knowledge about vibration analysis.



### Ordering Information

VIB-CT-50035

**CMT Vibration Meter Marine**  
(Including one acceleration sensor)

VIB-CT-50030

**CMT Vibration Meter Marine PLUS**  
With Memory and PC software  
(including one acceleration sensor)

VIB-CT-50017

**PELTOR Heavy Duty Headphone**  
Signal: 8 Ohm / 0.5 W

VIB-CT-50075

**Transport Case for VibrationMeter**



A lubrication mode allows monitoring and control of lubrication processes of grease lubricated machinery. This ensures proper lubrication and on the other hand spares costs and avoids damages due to over lubrication. Define the values of the shown limits specifically to your set up.

The device offers additionally an integrated IR temperature probe, a stroboscope and flash light which are valuable tools for the day to day work.

The "PLUS" version of the device allows storing or all data into an internal memory and evaluation with an external PC software at a later stage. As part of the delivery of the PLUS version our customers get the powerful data diagnostic software for storage and evaluation of vibration and technical data. Collecting data with the integrated Route function has never been easier. The software allows trending and a deeper analysis on site or at remote locations.

The software allows engineers to plan measurement routes and upload these to the device so that every crew member is able to collect the data.

With the purchase of the **Vibration Meter Marine** you get everything you need to start right away. Scope of delivery includes the device, acceleration sensor, DDS software (PLUS version only) and accessories all in a small rugged case for storage in between usage.

Optional high quality headphones are available for the acoustic evaluation of the bearings. Using the headphones an experienced user is able to spot problems in seconds.

Both experts and users without knowledge of vibration analysis can use the device immediately. For the latter the FASIT-Mode (fault source identification tools) has been introduced for simple

## Specification Vibration Meter Marine

Input	1 x ICP powered accelerometer 100 mV/g (60g)
Display	2.2 inch / 54 mm (240 x 320 pixel) colour display
Output	1 x AC 8 Ohm / 0.5 W signal for external headphones
Velocity	10 - 1000 Hz
Acceleration	500 - 16 000 Hz
Stroboscope	10 - 18000 rpm
Power	2 x AA batteries for 8 hours operation
Operating Temp.	-5 – 50°C
Dimensions	170 x 85 x 40 [mm]
Weight	380 g device including battery / 590 g complete

and rapid damage analysis. There is an immediate analysis of the problem according to the "traffic light" principle.

Already at the first measurement simple pictograms show whether a lubrication problem, an unbalance, loose parts or a bearing damage is present.

This single meter undertakes:

- FASIT Expert System
- RMS Vibration Level
- Bearing Lubrication

With this unique measuring device, unskilled users can perform following additional measurements:

- IR-Temperature
- Stroboscope / Speed
- Torch
- Headphones

In addition it incorporates a handy inspection torch.

### Your benefits:

- Specifically made for the needs and challenges of the Marine industry
- Easy & fast trending
- Quick diagnosis of the machines condition via simple traffic lights.
- Optional route measurements with free supplied software customized for the Marine sector

- Easy to understand, easy to use
- All results obtained can be directly used and understood by the user on board.
- Set the measuring limits according to the specific of your machinery
- Bright colour display for outdoor use

### Using Headphones

The device does allow connecting headphones to this instrument and listen to vibration signals. Do not consider this method out of date! If you measure transmissions or slow-running bearings, you will quickly understand its usefulness. With a little bit of experience this will allow you to distinguish good bearings from bad bearings. You can also hear the gear mesh in case of gearboxes. Last but not least this is an excellent method to hear if a bearing is lubricated well. If you use this while lubricating your bearing you know exactly when the bearing is well lubricated. This avoids over or under lubrication which can both be critical for your equipment.

With its excellent attenuation, the The CMT Headphones offers unique acoustic performance in very high noise environments. The proven and durable design ensures high comfort levels, allowing long term use under very tough conditions.

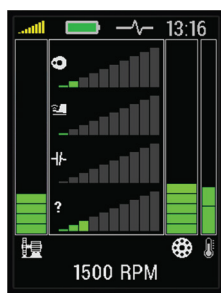

Machine OK



Unbalance



Misalignment



Bearing Faults

# Vibration Meter

**Vibration Meter** is a revolutionary instrument with a completely new design! The operation of the instrument is so easy that anybody can learn to use it very quickly. The instrument uses the colours green, yellow and red to display the status. Determination of individual machine or bearings defect types is done directly during operation, without a need to use a computer or software.

CMT **Vibration Meter** is sold as complete set with a quality accelerometer, coiled cable, magnetic base, transit case and optional headphones. You can connect headphones to this instrument and listen to vibration signals. Do not consider this method out of date! If you measure transmissions or slow-running bearings, you will quickly understand its usefulness.

Instruments in this cost-effective category have been able to measure only total vibration values so far. But the **Vibration Meter** is different. For each point on the machine this device produces many different measurements:

## Examples of the different modes:

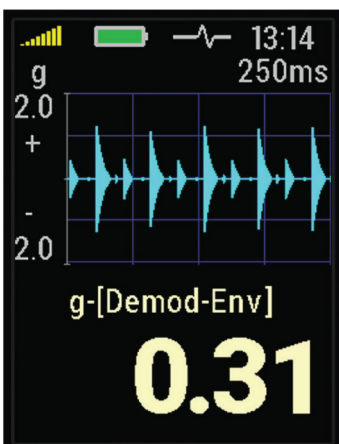
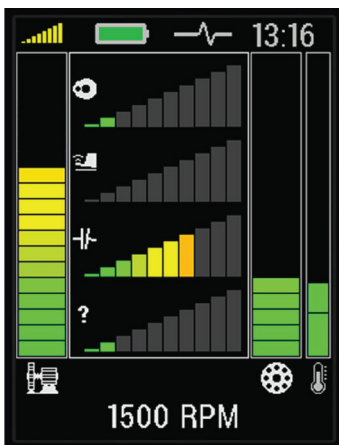
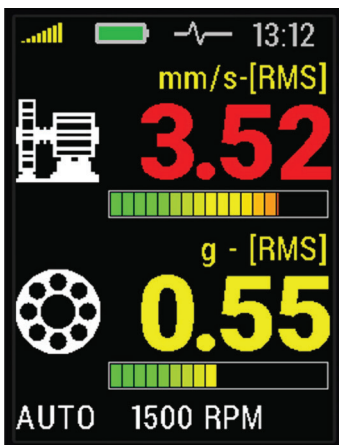

## Unbalance, looseness and misalignment, lubrication and bearing damages

This screen is all you need for a quick diagnosis. There is an overview by traffic light of unbalance, looseness, misalignment, lubrication condition and damages of the bearing.

RPM is automatically detected and displayed at the bottom of the screen.

This screen has been introduced especially for users with no or limited experience in vibration analysis.

## RMS Vibration levels

The device measures the RMS vibration level; and compare with the severity limits of ISO10816-3. Readings changes in Traffic Light colour when an exceeding occurs.

Bearing temperature is measured by infra-red and indicated in traffic light. An overheating of the bearing can be easily identified as a RED bar as shown in the figure (left side). Temperature reading in °C and °F is shown in another screen.

RPM is automatically detected and displayed at the bottom of the screen.

## Bearing fault detection

**Vibration Meter** measures the g-ENV, which represents the condition of the bearing. **Vibration Meter** also display the vibration time signal.

You can visualize the vibration impact due to bearing fault by looking at its time signal. It is useful in differentiating whether the increase in g-ENV is due to bearing fault or just lack of lubrication

Listen to the vibration signal through the audio output is a proven technique for bearing fault detection especially for slow rotating machine.



## Ordering Information

VIB-CT-50001

### CMT Vibration Meter

(Including one acceleration sensor)

VIB-CT-50022

### CMT Vibration Meter PLUS

With Memory and PC software  
(including one acceleration sensor)

VIB-CT-50031

### CMT Vibration Meter Ex

With Memory and PC software  
(including one acceleration sensor)

VIB-CT-50017

### PELTOR Heavy Duty Headphone

Signal: 8 Ohm / 0.5 W

VIB-CT-50075

### Transport Case for Vibration Meter

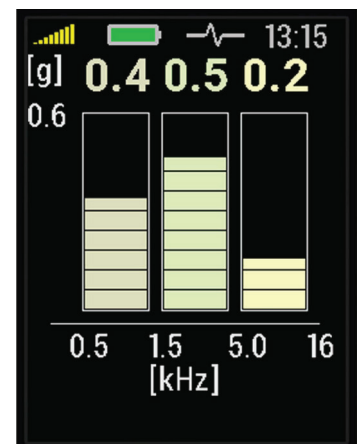

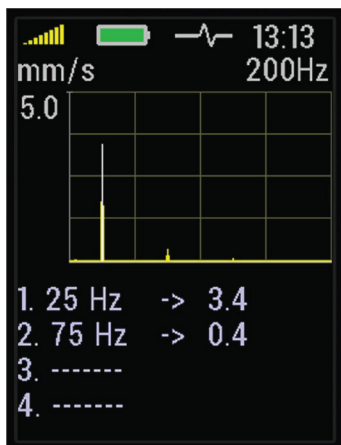

### Vibration Spectrum (FFT)

The **Vibration Meter** measures the FFT spectrum in the range of 0-200 Hz and displays the most three dominates peaks including the velocity value in mm/s. The information is useful for detection of unbalance and looseness.

### Stroboscope

The build-in stroboscope inside the **Vibration Meter** represents the unique innovation in the handheld vibration equipment. A high intensity LED is being used.

The stroboscope is very handy for inspection of rotating or moving machinery (belt, fan, coupler...). For example, missing screw can be seen without stopping the machine - can be a big cost saving. The device can automatically detect the rotating speed of the machine and freeze the movement by setting its flashing frequency the same as the rotating parts. Frequency can also be set manually.

**The Vibration Meter Plus is a step further in the long term history of the Vibration Meter production at CMT.**

It is the same instrument as the standard device but includes on top a memory and an USB connector for data transfer. The measured data can be stored in the device and transferred to a PC.

The **Vibration Meter Plus** can be used as a data collector. Together with the newly developed data acquisition software (DDS) it becomes a really handy tool.

The **Vibration Meter** is a multi-function portable meter that bridges the gap between the basic Vibration meter and advanced FFT data collector / analyser.

It is a complete machine condition monitoring system that gives results without the use of a computer or laptop. It is designed for the technician, engineer and consultant who needs to analyse a rotating machine on-site without investing and carrying expensive instruments to site. Using the CMT **Vibration Meter** cannot be easier!

Both experts and users without knowledge of vibration analysis can use the device immediately. For the latter the FASIT-Mode (fault source identification tools) has been introduced for simple and rapid damage analysis. There is an immediate analysis of the problem according to the "traffic light" principle.

Already at the first measurement simple pictograms show whether a lubrication problem, an unbalance, loose parts or a bearing damage is present.

This single meter undertakes:

- FASIT Expert System
- RMS Vibration Level
- Three band spectrum
- Time Wave Form
- FFT spectrum

With this unique measuring device, unskilled users can perform following additional measurements:

- IR-Temperature
- Stroboscope / Speed
- Torch
- Headphones

In addition it incorporates a handy inspection torch.

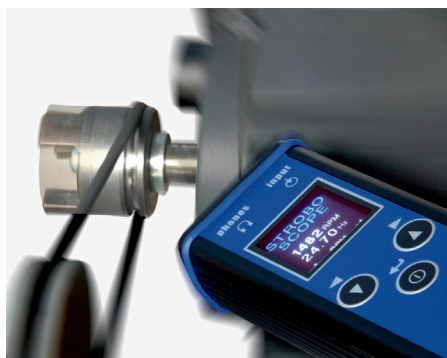

### Specification Vibration Meter

Input	1 x ICP powered accelerometer 100 mV/g (60 g)
Display	2.2 inch / 54 mm (240 x 320 pixel) colour TFT display
Output	1 x AC 8 Ohm / 0.5 W signal for external headphones
Memory (PLUS version only)	4 MB (900 measurements of 800 lines or 2048 samples time signal)
Interface	USB-C 3.0, 2.0 compatible
Velocity	10 - 1000 Hz
Acceleration	500 - 16 000 Hz
Displacement	1 - 1000 Hz
Velocity Spectrum	0 - 200 Hz
Stroboscope	10 - 18000 rpm
Power	Li-Ion battery, 15 hours of continuous operation
Operating Temp.	-5°C - 55°C
Dimensions	170 x 85 x 40 mm
Weight	380 g device including battery / 590 g complete



The Vibration Meter is now also available in an Ex version. All basic vibro diagnostic measurements are available.



Overall Values, FFT Spectrum, Time signal, Frequency bands, Route measurement and Expert system. You can listen to the signal with the headphones supplied with every unit.

The **Vibration Meter Ex** communicates with the DDS software, which you can download for free from the website.

The new **Vibration Meter Plus** does measure the same data as the standard **Vibration Meter**.

### Vibration Meter Ex - ATEX class

II	Non-mining
2	Zone 1
G	Gas atmosphere
Ex ib	Principle of protection: Intrinsic Safety En 60079-11, Zone 1
IIC	Gas group - Acetylene, Hydrogen
T4	Temperature class 135°C
Gb	Equipment Protection Level - Zone 1 (high protection)

### Velocity [mm/s, ips]:

RMS 10 - 1000 Hz  
 Peak 10 - 1000 Hz  
 Spectrum 1 000 Hz 800 lines  
 Time Waveform 10-1000Hz 2048 samp.

### Acceleration [g]:

RMS 500 - 16000 Hz  
 Peak 500 - 16000 Hz  
 Spectrum 16000 Hz 800 lines  
 Time Waveform 1-16000 Hz 2048 lines  
 Demod RMS 500 - 16000 Hz  
 Demod Peak 500 - 16000 Hz  
 Demod Time Waveform 500 - 16000 Hz  
 Demod Spec. 500 - 16000 Hz 800 lines

### Displacement [µm, mil]:

RMS 2 - 100 Hz  
 0-Peak 2 - 100 Hz  
 Peak - Peak 2 - 100 Hz

### Temperature measurement

0 - 380°C  
 32 - 716°F

### LED Stroboscope

0,17 - 300 Hz (10 - 18000 rpm)

## Grease Meter

**The Grease Meter is a plant tool used for monitoring and control of the lubrication process. It measures the actual bearing lubrication status and informs the operator when the lubrication state is optimal.**

The instrument helps to ensure that Bearings will not be under or over lubricated.

The use of the **Grease Meter** extends the bearings life and avoids wasting lubricant. Headphones can be connected to listen to the bearing condition. The device is simple to operate and also enables you to perform basic measurements and diagnosis of bearing condition.

With the Software provided it is possible to load a measurement route to the device.

The instrument is supplied as a complete measurement kit including an industry standard piezoelectric sensor, magnet and coiled cable for industrial use.

The lubrication status is indicated by traffic light colours:

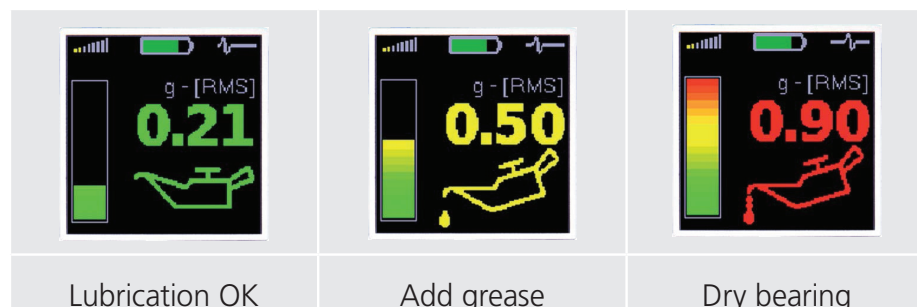

### Ordering Information

VIB-CT-50023

#### Grease Meter

(Including one acceleration sensor and grease gun)

VIB-CT-50024

#### Standard Grease Gun

VIB-CT-50017

#### PELTOR Heavy Duty Headphone

Signal: 8 Ohm / 0.5 W

## 2. Vibration Analyser

### Vibration Analyser VA3Pro

**CMT Vibration Analyser VA3Pro is a professional and robust 3 channel Vibration Analyser which is a valuable tool for maintenance engineers for fault diagnosis and data collection.**

The **Vibration Meter VA3Pro** is equipped with 2 signal inputs plus 1 tacho / trigger input to measure the speed / rpm. The second signal input offers connectivity to a triaxial sensor allowing to measure all 3 channels simultaneously.

The simple to understand expert system can automatically detect machine faults such as unbalance, looseness, misalignment or bearing faults.

There is a non-contact IR temperature sensor allowing immediate bearing temperature measurement as well as a LED light which can be used as stroboscope or torch.

The **Vibration Meter VA3Pro** has been designed for one-handed operation. With a weight of just 780 g and a battery live time of more than 10 hours of operation, the device is suitable for long route measurement.

The **Vibration Meter VA3Pro** can be configured according your requirements by choosing optional modules.

Optional modules can be purchased at a later stage and downloaded to the instrument without the need of sending the unit back to our factory.

#### Standard Test Modes:

- Standard Vibration Meter
- Speed / Stroboscope
- Expert System "FASIT" – Fault Source Identification Tool

#### Optional Test Modes:

- Analyser
- Balancer
- Route Measurement
- Data Recorder
- Run-Up
- Ultrasound

#### Ordering Information

VIB-CT-50016

##### Vibration Analyser VA3Pro

(Including one acceleration sensor and a case)

VIB-CT-50117

##### Vibration Analyser VA3Pro EX

#### Optional Test Modes

VIB-CT-50025	Analyser Mode
VIB-CT-50026	Route Mode
VIB-CT-50027	Balancer Mode
VIB-CT-50028	Recorder Mode
VIB-CT-50034	Run-Up Mode
VIB-CT-50037	Ultrasound

VIB-CT-50038

#### US-Microphone

VIB-CT-50006

#### Laser Tacho Probe

VIB-CT-50040

#### Silicone Protection Cover for VA3Pro



Meter



Expert system



Stroboscope



Route (Option)



Balancer (Option)



Analyzer (Option)



Recorder (Option)



Run-Up (Option)



Ultrasound (Option)



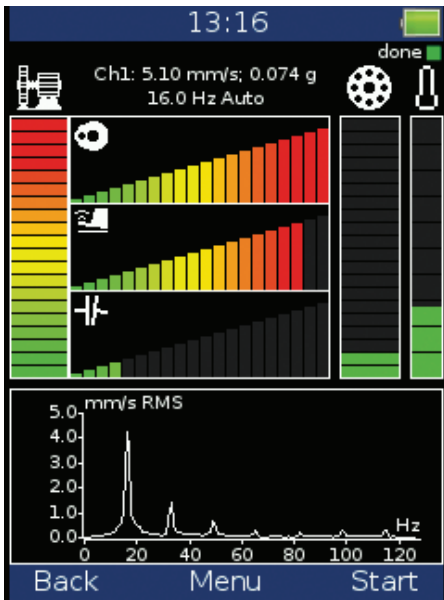

**EX rated device:**

The multiple features exclusive to the EX-variant:

- Certified for extreme working conditions
- Intrinsically safe 3-channel analyser
- High ATEX rating
- Protective shielding from ignition sources and conductive dust
- Sealed against occasional gas, mist and vapours

Designed for the engineer that needs a reliable device in the harsh conditions of hazardous industries. The EX variant of the VA3Pro protects human life as well as equipment.

Take advantage of multi axis sensors, speed probes and all the other features you can find in the regular version.

**Specification Vibration Analyser VA3Pro**

Processor	ARM Cortex A8 / 1GB RAM
Input	3 x AC/ICP powered accelerometer 100 mV/g or 1 x triaxial sensor 3 x DC ± 24 V / 4-20 mA 1 x Tacho / rpm input 0.5 Hz – 1000 Hz
Display	240 x 320 pixel colour TFT display
Memory	8 GB
Interface	USB 3.0, 2.0 compatible
Frequency ranges	0.5 Hz – 25.6 kHz / max sample freq. 64 kHz
FFT spectrum lines	25 – 25 600 lines
Cursor	Single, Harmonics, Sidebands
Scaling	Linear and logarithmic, both X and Y axis
Window	Rectangular, Hanning, Exponential, Transient
Stroboscope	60 – 6660 rpm
Power	Li-Ion battery pack, more than 10 hours <sup>(6 for EX device)</sup>
EX certification code	II 3G Ex ic op is IIC T3 Gc <sup>(EX Device only)</sup>
Operating Temp.	(-10) – 50°C
Dimensions	230 x 82 x 32 mm
Weight	0.78 kg

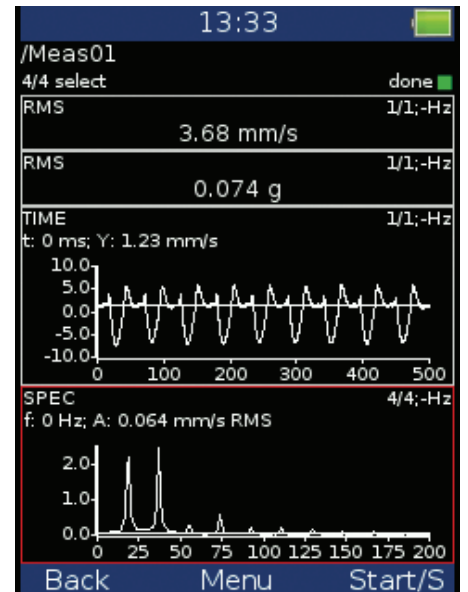
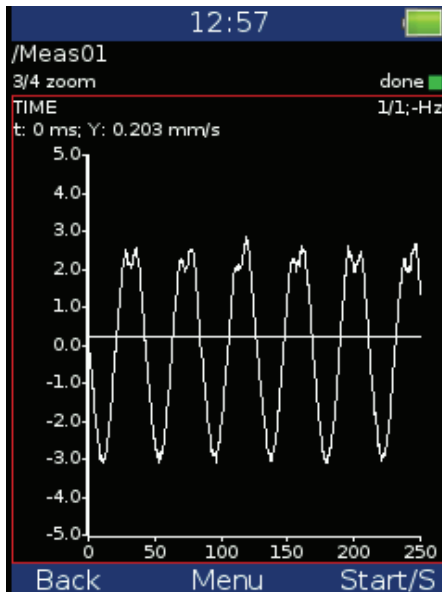

# Vibration Analyser VA5Pro

**CMT Vibration Analyser 5 is a professional and robust 4 channel Vibration Analyser / Recorder, which is a valuable tool for maintenance engineers for fault diagnosis, balancing and data collection / recording.**

**The new Pro contains these measurement modes:**

- Signal Recorder
- Signal Analyser
- Data Collector (Route measurements)
- Run Up (Coast Down) measurements
- Balancer
- FASIT – Fault Source Identification Tool
- Lubrication Control
- Ultrasonic Mode
- Octave Analysis
- Thermal imaging
- Calculator



**Key features:**

- FASIT - Fault Source Identification Tools
- FFT spectrum with 25,600 lines
- 4 AC + tacho + 4 DC channels (temp. pressure...)
- Balancing Advisor helps you with balancing

Measurement of 4 channels simultaneously gives a lot of flexibility in fault diagnosis. For instance, you can get a good insight of the alignment by measuring the radial and axial vibration across the coupling of the motor and pump.

64GB allows 20 hours continuous recording of 4 channel raw signals up to 25.6 kHz. Even under pressure, you don't have to worry that important data could be missed.

**Some examples of the different modes:**

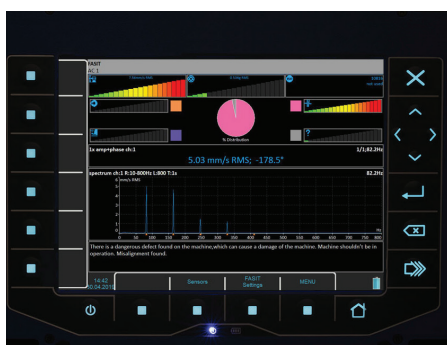

## FASIT - Fault Source Identification Tools

FASIT allows immediate assessment of the overall vibration severity according to ISO10816-3 and identification of the following faults using colour scale:

- Bearing fault
- Unbalance
- Misalignment
- Looseness



FASIT is a handy tool for even an experienced vibration analyst.

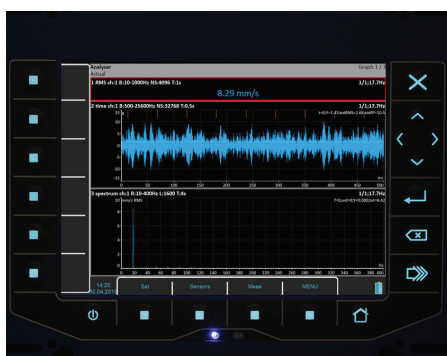

## Simultaneous Measurement

Readings can be taken in parallel for a single measurement point on 4 channels plus the speed probe, which saves time and improves consistency of the gathered data especially when the machine speed or running condition varies with time.





### Balancing

Vibration Analyser provides a professional 2-plane balancing function.

The whole balancing process will be on screen guided with easy-to-understand diagrams and instructions.

The weights will be automatically splitted and calculated for machinery where available locations for the weights are limited, e.g. a fan.

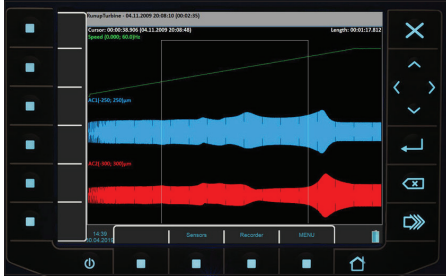

### Data Collector

Vibration Analyser can be used as a Data Collector for routine data collection. Parallel Measurements are performed simultaneously, that reduces the time needed for the data collection at each measurement point. It also improves consistency of the data especially when the speed or process condition of the machine varies with time.

For experienced users, historical data can be downloaded for on-site trending and comparison, so that a diagnosis can be made immediately.

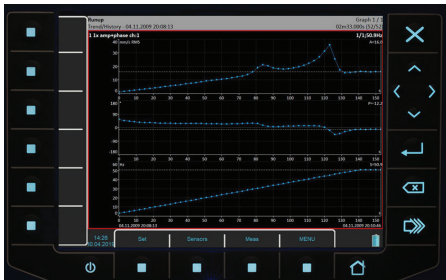

### Run-up / Coast Down

Run-up / Coast-down or Vibration Time History (overall & spectrum vs time) can be easily carried out on Vibration Analyser. Raw time data can also be recorded as a backup for critical machinery. 4 DC Process Parameters can be measured at the same time for correlation analysis with vibration readings.

Different graphs are available for run-up / coast-down analysis: Bode plot (amplitude and phase vs rpm), Nyquist plot, Waterfall plot (vs RPM or Time) or Cascade plot

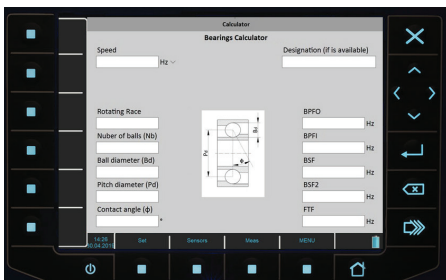

### Calculator

The Calculator function not only is a simple calculator or converts units very easily but also includes bearing fault frequencies, belt frequencies and gearbox calculators.

## Specification Vibration Analyser VA5Pro

Processor	Atom 1.9 GHz / 2 GB RAM
Input	4 x ICP powered accelerometer 100 mV/g 4 x DC ± 24 V / 4–20 mA 1 x Tacho / rpm input 0.5 Hz - 1000 Hz
Display	1125 x 800 pixel colour LCD display
Memory (Internal SSD)	64 GB, max 16 GB for one route.
Interface	USB 3.0, 2.0 compatible
Frequency ranges	0.35 Hz – 90 kHz / max sample freq. 196,6 kHz
FFT spectrum lines	100 – 3267800 lines
Cursor	Single, Harmonics, Sidebands
Scaling	Linear and logarithmic, both X and Y axis
Window	Rectangular, Hanning, Exponential, Transient
Order analysis parameters	1/2 – 10th order
Power	Li-Ion battery pack, 8 hours measurement
Operating Temp.	-10 – 50°C
Dimensions & Weight	295 x 230 x 49 mm, 2.0 kg
Camera(s)	5MPx autofocus, thermal imaging camera (optionally)

### Ordering Information

VIB-CT-50065

#### Vibration Analyser VA5Pro

(Including one acceleration sensor and a case)

VIB-CT-50006

#### Laser Tacho Probe

VIB-CT-50038

#### US-Microphone

VIB-CT-50066

#### Transport Case for VA5

VIB-CT-50017

#### PELTOR Heavy Duty Headphone

VIB-CT-50067

#### Thermal Imaging Camera

Range: -10°C ~ 150°C

VIB-CT-50047

#### Acceleration Sensor Complete push /pull

(Including spiral cable and magnet base)

Sensitivity 100 mV/g

Resonance Freq. 30 kHz

Operating Temp. -55 - 140°C

Connector push / pull

## Pocket Analyser



The Pocket Analyser is a pocket sized 4 channel vibration analyser.

Connect the **Pocket Analyser** to any computer by USB and use the unit for data analysing, collecting and the recording of vibration signals.

The instrument is enhanced by modules for dynamic balancing, measurement of run up and coast down and acoustic measurement mode.

The instrument is equipped with an expert system which automatically detects machinery faults.

The instrument is powered directly by USB connection so no external power is needed.

### Ordering Information

VIB-CT-50032

**Pocket Analyser**

(No sensor included)

VIB-CT-50047

**Acceleration Sensor Complete** push / pull

(Including spiral cable and magnet base)

Sensitivity 100 mV/g

Resonance Freq. 30 kHz

Operating Temp. -55 - 140°C

Connector push / pull

VIB-CT-50006

**Laser Tacho Probe**

VIB-CT-50038

**US-Microphone**

### Specification Pocket Analyser

Input	4 x ICP powered accelerometer 100 mV/g 4 x DC $\pm$ 24 V / 4–20 mA 1 x Tacho / rpm input 0.5 Hz - 1000 Hz
Interface	USB 3.0, 2.0 compatible
Frequency ranges	0.35 Hz – 90 kHz
FFT spectrum lines	25 – 3267800 lines
Power	5V over USB
Operating Temp.	-10 – 50°C
Dimension	110 x 115 x 35 mm
Weight	0.25 kg

Connect the CMT **Pocket Analyser** to your laptop or PC and get all functions of 4 channel Vibration Analyser VA5Pro.

The free download of the Virtual Unit software enables you to perform all functions of the analyzer on your computer.

The pocket size 4 channel Vibration Analyser provides the following input channels:

- 4 AC, ICP® (On/Off),
- 4 DC,
- 1 TACHO



## Strobo

The build-in stroboscope inside the Vibration Meter represents the unique innovation in the handheld vibration equipment. A high intensity LED is being used.

The **Stroboscope** is very handy for inspection of rotating or moving machinery (belt, fan, coupler...). For example, missing screw can be seen without stopping the machine - can be a big cost saving. The device can automatically detect the rotating speed of the machine and freeze the movement by setting its flashing frequency the same as the rotating parts. Frequency can also be set manually.

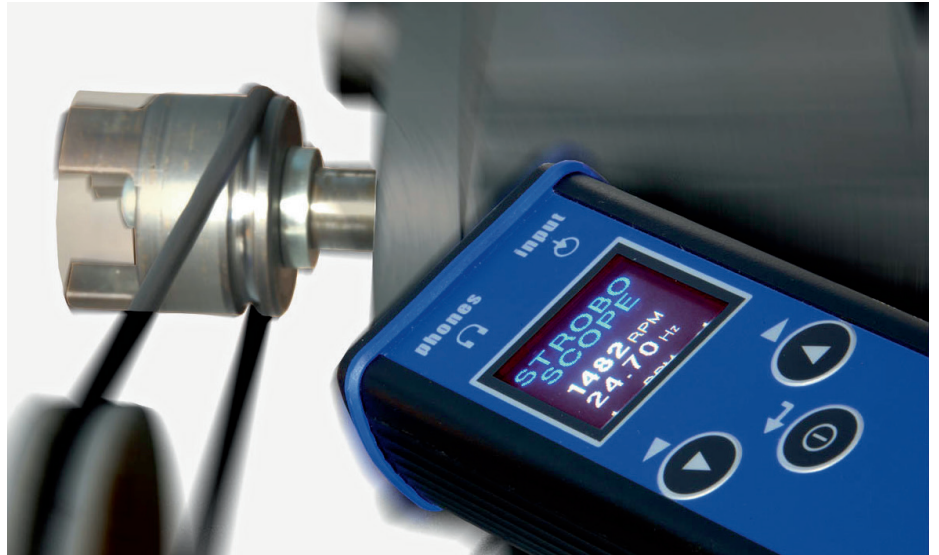

**Stroboscope** enables to ostensibly stop rotating or generally periodic (reciprocating) motion of a machine. It allows also to find out the speed of rotation or to perform synchronized measurements without having to use reflective markers on the shaft. The **Stroboscope** uses three ultra-bright LEDs with optical system as a source of flashes. The device is equipped with a colour graphic display and 3 operational buttons.

Operation is very easy and intuitive. Two standard or rechargeable AA batteries are used for powering. The **Stroboscope** can be used also as a tachometer by connecting an external speed probe.

### Ordering Information

VIB-CT-50053

**Strobo**

## VIB Simulator



The **VIB Simulator** device behaves like a standard ICP® acceleration sensor with a sensitivity of 100 mV/g. The unit generates precise amplitude levels on 80 Hz and 8 kHz frequencies. The **Vib Simulator** enables the user to check measurement precision and functionality of analyzers, vibration meters, protection and monitoring systems.

### Key features:

- Simulates the acceleration sensor 100 mV/g
- Two output connectors - MIL, BNC
- Quick check of cables and devices

### Ordering Information

VIB-CT-50042

**VIB Simulator**

Simulates one standard sensor  
100 mV/g

### 3. Vibration Monitor

The series of Vibration Monitors are powerful online monitoring and diagnostics systems. They have been designed to increase the reliability of strategic rotating machinery.

The Vibration Monitor systems can operate as an independent monitoring system or they can be used as extension of an existing protection system.

The Vibration Monitor software is designed for the control of the data collection and archiving. Setting up the program allows to easily configure the required measurements.

The software enables the real time online display of the current measurement values on the predefined channels. The DDS software system is designed for the follow up processing and archiving of all the collected data.

The setting and control of all Vibration Monitors is done in DDS software. The setting has never been easier. The only thing which needs to be done is to create the tree of machines, measurement points, required readings and assign them to appropriate channels. Then you just press START and the readings are done automatically.

#### Data acquisition

Data acquisition can be done conventional with fixed defined time intervals. Some important value changes in between those measurements can be lost with this method. Every measured data is saved, so the values with no information (same value as before) are saved and take valuable space.

To improve this we have developed a new Adaptive Algorithm of Data Acquisition. Data are measured continuously, so nothing can be missed out. But only selected values are saved. If the measured value is not changing significantly, it is not saved. Adaptive Algorithm selects which data to save and which not.

Single Vibration Monitor modules can be easily composed together creating a wide channel system. Different versions of the Vibration Monitors can be mixed together in one system all controlled by one software on one computer.

There are 3 version of the Vibration Monitor available.

- A3800 Vibration Monitor Compact
- A3716 Vibration Monitor Standard
- A3716 Vibration Monitor Plus

The **A3800 Vibration Monitor Compact** is a 4 to 16 channel on-line monitoring and diagnostic system. The compact size enables it to be placed directly on the DIN rail in a switchboard.

The unit has an optional number of AC and DC input channels - 4, 8, 12 or 16. AC and DC channels are separate. This means that the 4-channel configuration allows you to connect 4 AC and 4 DC channels. Depending on the number of active input channels, it uses 1 - 4 independent TACHO inputs.

The number of active channels can be extended by purchasing additional licenses. Each group of 4 channels allows fully simultaneous measurements. Groups of 4 input channels are switched via an internal multiplexer.

The Vibration Monitor Compact is available with an optional WiFi module.

The **Vibration Monitor Standard and Plus** system contains 16 AC, 16 DC and 4 TACHO inputs. All channels are measured simultaneously.

The Standard version only needs 2 Slots (90 mm height) in your 19" aluminium rack while the Plus version will need 3 Slots (135 mm height). The Compact version is placed directly on the DIN rail in the switchboard.

The plus version also offers additional connections like 16 relay outputs, 16 (4-20 mA) current loops and 16 BNC outputs.



Vibration Monitor Compact

#### Ordering Information

VIB-CT-50044

#### Vibration Monitor Plus (3U)

16 channel synchronous measurement

VIB-CT-50003

#### Vibration Monitor Standard (2U)

16 channel synchronous measurement

VIB-CT-50056

#### Vibration Monitor Compact

4 channel synchronous measurement extendable to 4x4 channel multiplex

VIB-CT-50057

#### Vibration Monitor Compact License

(licence for additional 4 channels)

VIB-CT-50058

#### Vibration Monitor Compact WiFi Module

WiFi Standard 802.11b/g/n

VIB-CT-50006

#### Laser Tacho Probe

SEN-CT-16910

#### Inductive Tacho Sensor

VIB-CT-50059

#### Data Manager

Setup of Online Systems



Vibration Monitor Plus (3U)



Vibration Monitor Standard (2U)

## APPLICATION SCHEME OF VIBRATION MONITOR UNITS

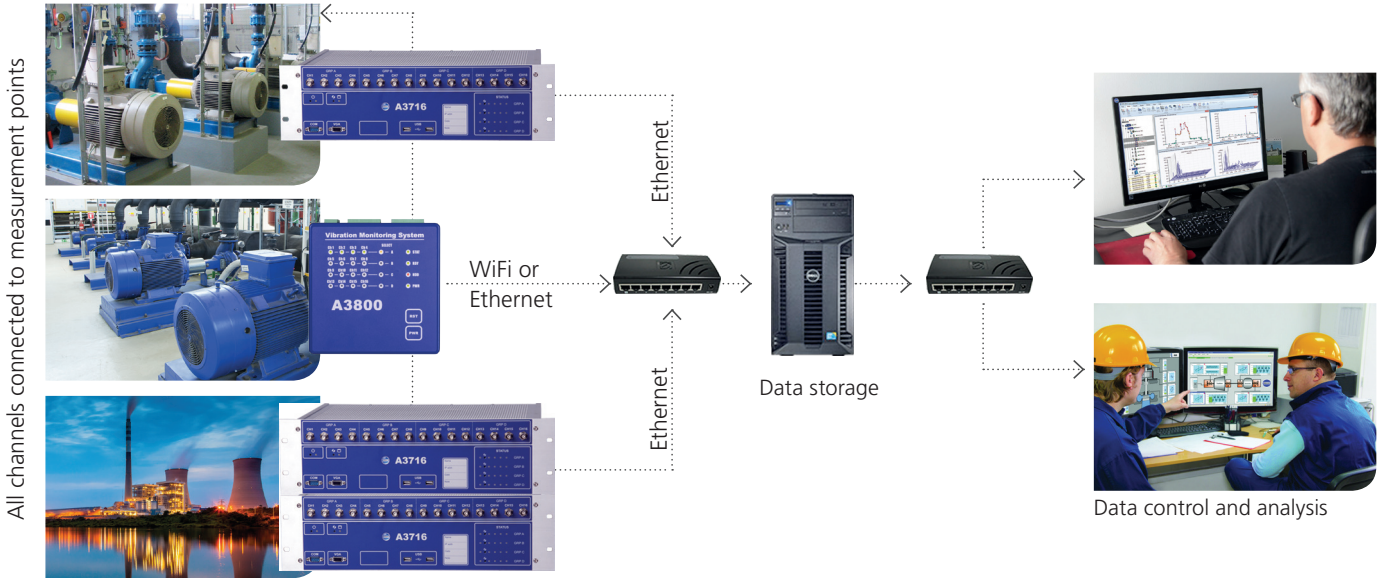

## SET UP AND CONTROL



- › The set up and control of the Online units is done by the Data Manager. The set up has never been easier. Storage of data and evaluation is handled with the DDS software.
- › The new data acquisition control system was developed for the Vibration Monitor. Now the unit reads the vibration continuously, not only at predefined time intervals. The adaptive algorithm saves the readings to the database as needed.
- › The Vibration Monitor unit continuously monitors the required machines and adaptively saves the readings to the data storage computer. The data is accessible from various workstations for control and analysis.
- › The great advantage of the DDS software is its very easy set-up. There is no difficult installation of the server anymore and no complicated set-up of parameters. The demands for transfer and data storage are minimized.



Vibration Monitor Compact - top



Vibration Monitor Compact - bottom



Vibration Monitor Standard rack mounted



Vibration Monitor Compact WiFi Module

### Key Features VM Compact

- Optional number of input channels
- 4 – 16 channels AC
- 4 – 16 channels DC
- 1 – 4 TACHO inputs
- Adaptive algorithm of data acquisition
- Compact size, DIN rail mounting

### Key Features VM Standard / Plus

- 16 x 4-20 mA (Plus)
- 16 channels AC
- 16 channels DC
- 4 TACHO inputs
- 16 BNC buffered outputs of signals from sensors (plus version only)
- 16 programmable relays outputs (plus version only)
- Adaptive algorithm of data acquisition

	Vibration Monitor Plus	Vibration Monitor Std.	Vibration Monitor Compact
<b>Dynamic Input Channels (AC)</b>			
Number of synchronous channels:	16 AC		4 x 4 AC
Frequency range:	90 kHz (196.6 kHz sampling frequency)		25,6 kHz (65,5 kHz sampl.)
Input range:	+/- 12 V (only one range, no gains)		
Measurement timing:	Fully synchronous 16 channel		Fully synchronous 4 channel
A/D Resolution / dynamic range:	24 bit input, 64 bit double floating point / 120 dB		
Channel configuration:	Voltage or ICP (individually for every channel) - 100 kOhm		
Input type / accuracy:	Acceleration, velocity, displacement, / < 0.5%		
High pass filter:	1 Hz -12.8 kHz (user definition)		
Low pass filter:	25 Hz -25.6 kHz (user definition)		

<b>RPM Input Channels</b>			
Number:	4 independent rpm inputs		1 to 4
Speed range / accuracy:	0,8 Hz - 1000 Hz / < 0.5%		
Input range / impedance:	+ 10 V (only one range, no gains) / 80 kOhm		
Trigger level:	0.1 -9.9 V, user defined / positive or negative		

<b>Static Input Channels (DC)</b>			
Number:	16 DC		4 / 8 / 12 / 16 DC
Input range:	+/- 24 V or 4-20 mA		
Input impedance:	100 kOhm (VDC), 250 Ohm (mADC)		
A/D Resolution / accuracy:	12 bit input / 0.1% fsd		

<b>Additional In- and Output Channels</b>			
16 x Current loops	4 – 20 mA current outputs	---	---
16 x Relay outputs (NO,COM,NC)	Contains relay clamps	---	---
16 x BNC sensor signal on front	Dynamic input	---	---
4 x power output	2 x 5V / 1A and 2 x 12V / 1A	---	---
8 x Binary inputs	Logical inputs states 0 or 1	---	---

<b>General</b>			
Processor:	Intel Core2 - 2.5 GHz		Intel Atom E3815 - 1.46 GHz
RAM:	4 GB		4 GB
Internal data disk:	SSD 128 GB		SSD 32 GB
Power supply:	AC 110-240 V, 45-65 Hz		DC 12 V
Operating temperature:	-10°C - +50°C, 15°F - 120°F		
EMC:	CE tested		
Dimensions (in mm):	430 x 360 x 135	430 x 360 x 90	117 x 117 x 58
Weight:	6,2 kg	4,7 kg	0,8 kg

<b>Measurement Functions</b>			
Triggering:	Free run / impulse / external (voltage) (0,8-1000 Hz)		
Data acquisition:	Overall values / time signal / real-time FFT / envelope demodulation / ACMT low speed bearing measurement, order analysis / user band pass analysis / RPM measurement / DC measurement / orbit measurement / speed measurement		
Frequency ranges:	Max. 25,600 kHz (65,5 kHz sampling)		
FFT spectrum lines:	100 - 25600 lines		

<b>Communications</b>			
Interface:	Ethernet 1GB RJ45		
Output (monitor):	VGA (1 x front / 1 x rear)		HDMI
USB (keyboard and mouse)	2 x front / 2 x rear		2 x
COM Port	RS 232 1 x front / 1 x rear		---

## 4. Software

### Data Diagnostic Software

The vibration analysis software **DDS** is a powerful tool for storage and evaluation of vibration and technical diagnostics data. It allows the user to work with data collected by portable data collectors and online systems.

The full version includes all functions necessary for data transfer, evaluation, analysis and data storage. Using standard Microsoft OS logic the program is easy to understand and operate.

The common database for portable and on-line units is a unique feature of the **DDS**.

Optional instrument interfaces allow the user to connect all measuring instruments in a single database system.

This feature saves money and time. The DDS system also fully supports route measurements. The database of the **DDS** system uses SQL and ODBC standards to process data. It can also work with an SQLite database for customers who do not want to use MS SQL Databasis.

It is an open system which can receive and send information to other information systems.

The **DDS** system fulfils all network operation requirements. Several users at the same time may work with one database.

Output reports, data communication, a fast processing of output messages or reports were among the basic requirements imposed on **DDS**.

#### Ordering Information

VIB-CT-50004

**DDS Data Diagnostic Software**  
(Full access / no limits)

VIB-CT-50045

**DDS Data Diagnostic View Software**  
(No changes of the tree)

#### DDS Data Diagnostic Software

- Free update for new versions
- Routes and Tree concept
- Including Bearing database
- Aligned cursors in graph view
- No service database. All data are stored in one database
- Can be used with all devices.
- Free version available for Vibration Meter and Vibration Analyser VA3 (limited functions)

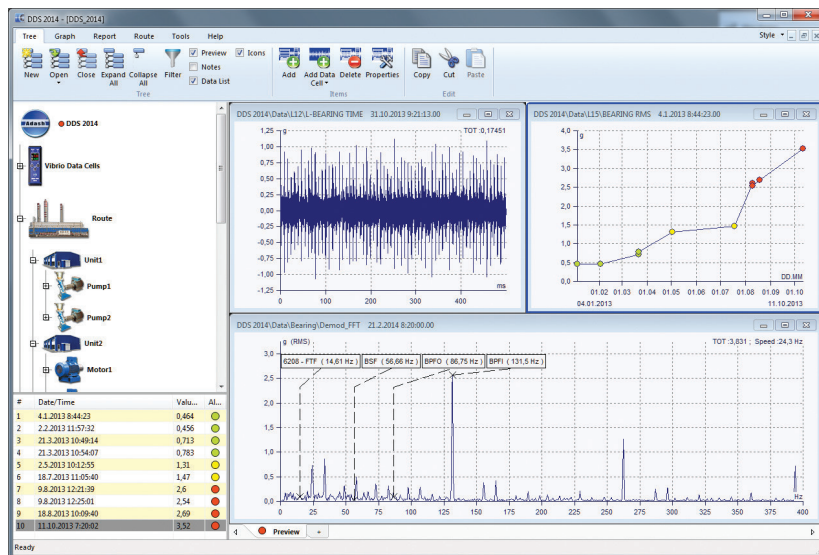

Different versions of the DDS-Software:

#### DDS

- Create all possible data cells
- Unlimited database size and numbers of databases
- Dongle key required.

#### DDS View

- Open and view all databases or data from all devices
- Unlimited database size and number
- No editing of tree items or data
- Dongle key required.

#### DDS Free

- Create only selected measurement types (all Vibration Meter measurement types)
- 200 MB limited database size
- Only one database

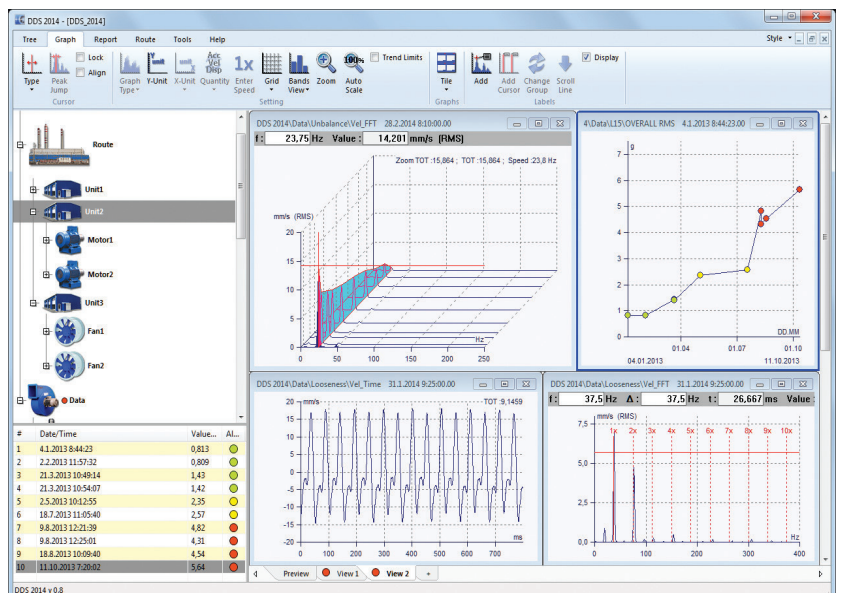

# Animated Deflection Shapes Software

## The Animated Deflection Shapes software is based on the method of operating deflection shapes.

This means that we visualize the vibrations of the machine by animation. During the animation the vibration movement is slowed down to very low frequency and the amplitude of the motion is increased so we can see the vibration.

It is a combination of vibration measurement and software processing.

The output of the method is vibration movement animation on one forcing frequency or on multiple forcing frequencies. The output of the method is easily understandable for everybody.

## Ordering Information

VIB-CT-50033

**ADS Animated Deflection Shapes Software**

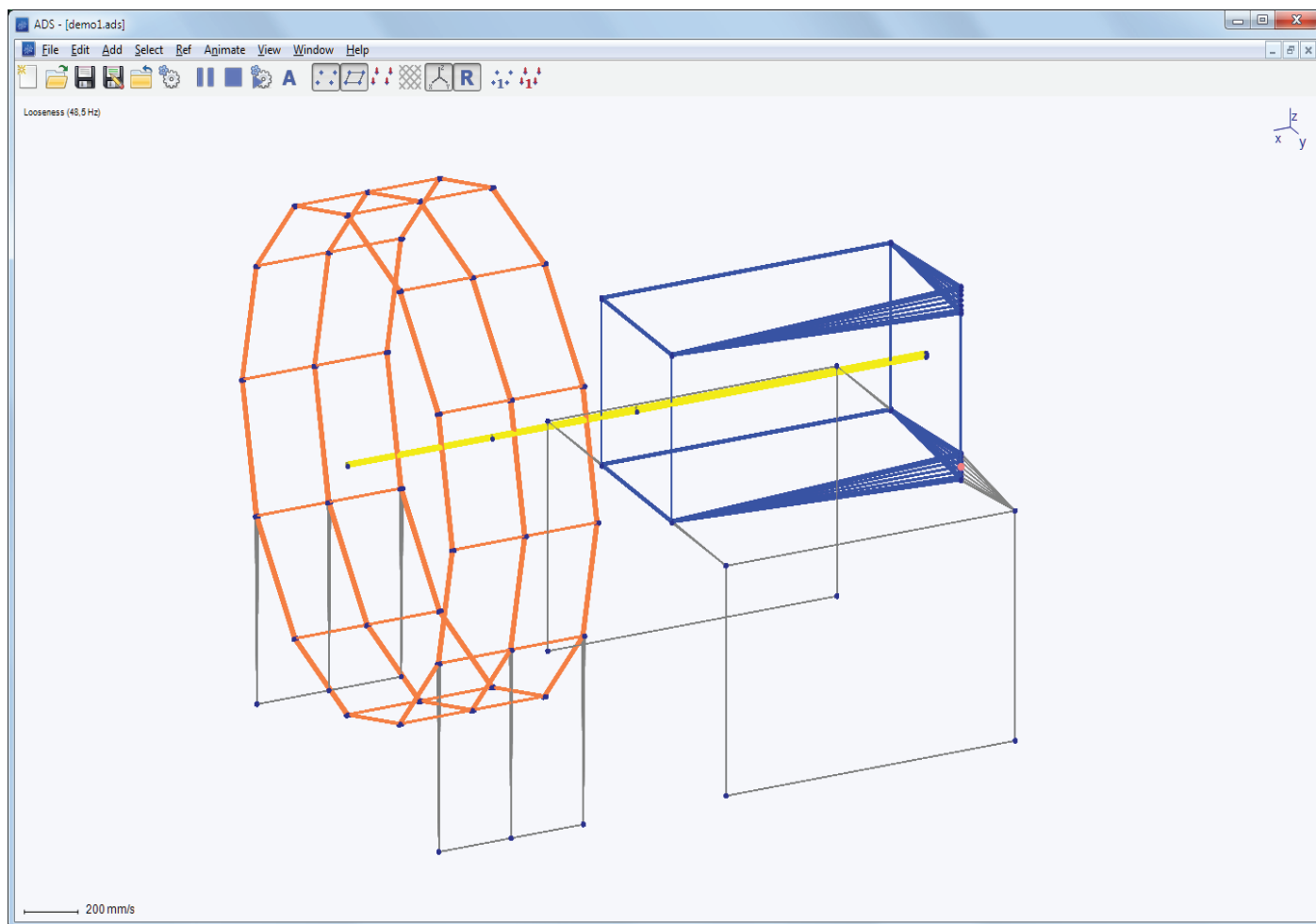

## 5. Spares and Accessories

### Sensor, Cables and Connectors

**Our range of AC 100 mV/g accelerometers is designed for use with all types of data collectors and online systems using two-wire constant current method of drive.**

The range includes standard, high performance premium accelerometers, each manufactured to the highest ISO standards and backed by our outstanding technical customer support services.

Options include sensitivities of standard 100 mV/g, or choose from: 10 mV/g, 30 mV/g, 50 mV/g, 250 mV/g or 500 mV/g.

The complete acceleration sensors do come with sensor, coiled cable and magnet since this is the most common combination for data collectors.



Acceleration Sensor Complete



US-Microphone



Acceleration Sensor Single



Laser Tacho Probe

#### Ordering Information

VIB-CT-50047

**Acceleration Sensor Complete** push /pull  
(Including spiral cable and magnet base)  
Sensitivity 100 mV/g  
Resonance Freq. 30 kHz  
Operating Temp. -55 - 140°C  
Connector push / pull

VIB-CT-50005

**Acceleration Sensor Complete** binder  
(Including spiral cable and magnet base)  
Sensitivity 100 mV/g  
Resonance Freq. 30 kHz  
Operating Temp. -55 - 140°C  
Connector Binder 712

VIB-CT-50012

**Acceleration Sensor Single**  
Sensitivity 100 mV/g  
Sealing IP68  
Resonance Freq. 30 kHz  
Operating Temp. -55 - 140°C  
Connector MIL2  
Mounting Thread 1/4"-28 UNF female

VIB-CT-50015

**MIL2 Connector for Acceleration Sensor**

VIB-CT-50038

**US-Microphone**  
Option for Vibration Analyser VA3 - VA5

VIB-CT-50006

**Laser Tacho Probe**  
Option for Vibration Analyser VA3 -VA5  
Option for Vibration Monitor

VIB-CT-50009

**5 m Extension Cable for Sensor**  
Push / pull or Binder 712

VIB-CT-50010

**10 m Extension Cable for Sensor**  
Push / pull or Binder 712

## Quick Connection Box



**The Connection Box is used as a terminal to collect the signals from multiple channels and to supply them for external readings.**

There is no need to check on every measurement point. Just connect your sensors to the Quick Connection Box and you can take all measurements at the box.

Easily switch from one Sensor to the next.

This high quality product is made from stainless steel and is IP 66 certified. That makes it perfect for the use on board of a vessel.

The Quick Connection Box is compatible with all of CMT's vibration devices. There are multiple output options available on request.

### Key features:

- Provides a terminal to take readings from accelerometers via a portable data-collector
- Multiple outputs via multiple connectors
- Compatible with all of CMT's vibration devices
- IP66 certified
- Intrinsically safe version available on request

### Specifications

Inputs	Via accelerometer
Single input M12	ø3.5-7 mm cable
Single input M20	ø7-13 mm multicore cable
Output	BNC as standard
Material	304 Stainless Steel
Termination	Klippon Type
EMC	EN61326-1:2013
Sealing	IP66

### Ordering Information

VIB-CT-50055

**Quick Connection Box 4 Channel**

VIB-CT-50119

**Quick Connection Box 2 Channel**

## Sensor Bases & Magnets



Magnet - Pole Piece



Magnet - Flat Face



Quick Fit Base for Sensor

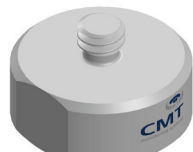

**As a standard connection to achieve reliable results it is intended to use a Measuring Pad on the machine with the magnet mounted to the sensor.**

CMT provides two different magnets for curved and flat surfaces.

The most optimal measuring results will be achieved with the newly designed CMT Quick Fit connection. This requires one Quick Fit Base attached to the sensor and on each measuring point a Quick Fit Measuring Pad which is also protected with a yellow cap while it is not in use.

Permanently installed sensors should have a bolt-on connection using the measuring pad with a stud.

### Ordering Information

VIB-CT-50029

**Magnet - Pole Piece**

Stud for Sensor 1/4"-28 UNF male

Diameter / Height: 25 / 18 mm

Pull Strength: 20 kg

VIB-CT-50021

**Magnet - Flat Face**

Stud for Sensor 1/4"-28 UNF male

Diameter / Height: 30 / 10 mm

Pull Strength: 25 kg

VIB-CT-50048

**Quick Fit Base for Sensor**

Mounting Thread quick fit

Stud for Sensor 1/4"-28 UNF male

Diameter / Height: 24 / 10 mm

Wrench size: 22 mm

## Measuring Pads

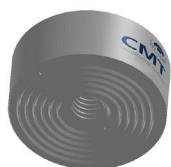

Measuring Pad for Magnet

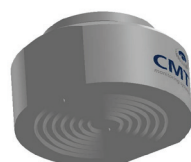

Quick Fit Measuring Pad

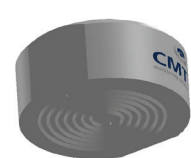
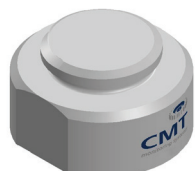

Measuring Pad for Studs

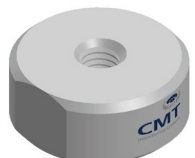

**To achieve a comparable measuring trend it is recommended to stick to the same routine at every measurement.**

To help with consistent measurements CMT is offering Measurement Pads.

The Measuring Pads are glued on the machine to guarantee that the same measuring spot is being used at every measurement.

Most important for good results is a tight and firm connection between sensor and machine. The established best practice is to use CMT Measuring Pads.

The Measuring Pads are equipped with a yellow protection cap for easy recognition and protection against any dirt or paint.

CMT uses specially packed rapid curing synthetic metal glue to permanently mount measuring pads on metal surfaces. Simple hand mixing ensures activation reaction between the concentrically packed components.

All loose material, rust and surface contaminants, including existing coatings, must be removed and the surface roughened by using an angle grinder etc.

### Ordering Information

VIB-CT-50051

#### Measuring Pad for Magnet (10)

Flat surface

(Including protection cap)

Diameter / Height: 24 / 10 mm

VIB-CT-50050

#### Quick Fit Measuring Pad (10)

Mounting Thread quick fit

(Including protection cap)

Diameter / Height: 24 / 10 mm

Wrench size: 22 mm

VIB-CT-50011

#### Measuring Pad for Stud (10)

(Recommended for permanent installation)

Mounting Thread M6 x 1 mm

Diameter / Height: 24 / 10 mm

Wrench size: 22 mm

VIB-CT-50052

#### Screw Studs (10)

Threads: M6 x 1 / 1/4"-28 UNF

VIB-CT-50018

#### Epoxy Metal Glue for Measuring Pads

Drying time: 2 hours at 20°C

Max. Temp: 120°C

Handling time:

Capacity: 10 - 15 pads

# Performance and Efficiency Monitoring

1. Mechanical Peak Pressure Indicator.....	76
2. PREMET M.....	77
3. PREMET X.....	78
4. PREMET Software.....	80
5. PREMET Online 24/7.....	84
6. Pressure and Temperature Calibration.....	85

## Diesel Performance Monitoring

Sea going vessels require large amounts of fuel to operate. Therefore diesel engine performance is paramount to a ship's owner's bottom line. Most marine diesel engines operate on lower-quality fuels that can cause ignition delays and incomplete combustion.

CMT's Diesel Performance Analysers can provide early detection of worn or damaged engine components such as piston ring leakage, burnt piston crown, exhaust valve leakage and much more. It also ensures that the engine is well balanced and the injection timing is correct. An optional feature is an acoustic emission sensor that measures fuel injection without penetrating the fuel system. This option delivers enhanced engine performance by utilizing some of the latest technological innovations designed specifically for marine engines.

### CMT provides five different systems:

- **Peak Pressure Indicator:** Easy, simple and efficient tool to measure peak pressure.
- **PREMET M:** Modern economic and easy to use device with all features needed.
- **PREMET X:** Ultra accurate device with a large colour display and advanced connectivity.
- **PREMET Online Single Sensor:** Similar to the PREMET X functionality but permanently wired up always ready to take a measurement.
- **PREMET Online 24/7:** Measures continuously the performance of the main engine so will not miss any problem.

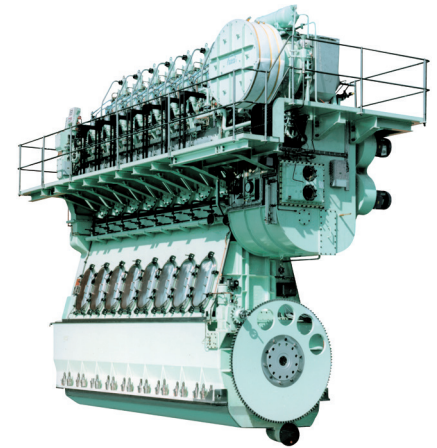

### Your benefits:

- Reduced fuel consumption
- Reduced spare parts purchases
- Reduced emissions
- Well balanced engine
- Correct ignition timing
- Overload protection
- Improved maintenance efficiency

## 1. Mechanical Peak Pressure Indicator

The CMT Peak Pressure Indicator is an easy, fast and cost effective way to maintain your diesel engines.

It measures the maximal firing pressure and the compression pressure of two and four stroke combustion engines. It helps balancing and optimising your engine and with that you will be able to make the most out of your engine and fuel.

By cutting the fuel for one cylinder for a short time you can easily detect any possible blow by to avoid unwanted loss of energy.



Optimising your engine cannot be easier with the help of the CMT **Peak Pressure Indicator**.

We have designed the new CMT **Peak Pressure Indicator** with the engineer on site in mind. It has been designed for easy operation and to protect its user in case of excessive cylinder pressure.

A safety glass gauge and protection by a blow out back wall are just two examples for our features to avoid accidents during the usage.

Every single device will be tested and calibrated according to our ISO 9001 quality standards and will be supplied with a calibration certificate proving the accuracy of the device.

### Your benefits:

- Prevents unbalanced peak pressure
- Detects blowbys
- Helps to avoid uncontrolled vibration
- Prevents loss of efficiency
- High accuracy at all speeds and pressure ranges
- Extremely robust
- Steel-gauge in safety construction

### Ordering Information

#### Peak Pressure Indicator Types:

DPA-CT-00140

#### Peak Pressure Indicator 140

Range: 0-140 bar

DPA-CT-00180

#### Peak Pressure Indicator 180

Range: 0-180 bar

DPA-CT-00220

#### Peak Pressure Indicator 220

Range: 0-220 bar

DPA-CT-00250

#### Peak Pressure Indicator 250

Range: 0-250 bar

DPA-CT-02000

#### Peak Pressure Indicator 2000

Double Scale

Range: 0-150 bar

0-2000 Psi

DPA-CT-03000

#### Peak Pressure Indicator 3000

Double Scale

Range: 0-225 bar

0-3000 Psi

DPA-CT-12116

#### Spare part set for Peak Pressure Indicator

## 2. PREMETS® M

Newly developed and part of CMT's modern range of PREMETS® diesel performance analysers the PREMETS® M is the way to go if you are looking for an economic approach to monitor your engines without sacrificing quality and accuracy. Brand new technologies give the user an unparalleled accuracy and will ensure you are getting results you can act on. Designed by marine engineers to be used from marine engineers the PREMETS® M helps balancing cylinder load, optimise injection timing and detect worn or damaged engine components and thus reducing the engine's operating cost.

Balancing the cylinder load helps extend engine life, increases efficiency, and reduces emissions to assist with environmental compliance.

Proper ignition timing reduces exhaust gas temperature and the rate of excess carbon build-up. Tuning the engine may reduce specific fuel oil consumption (SFOC). For each degree that the ignition is retarded SFOC increases by approximately 2%. The PREMETS® M may protect against costly downtime by implementing predictive maintenance.

Major defects can be easily detected. Engine maintenance can be planned, thus saving in parts and labour by changing engine parts based on need, not on timed intervals.

The PREMETS® M has a rugged housing and uses a Kistler PiezoSMART pressure sensor of latest design which is being connected to the indicator valve of the cylinder for a measurement. 4-stroke engines can be measured without pick up with high accuracy but to achieve an even higher accuracy a pick up can be used. For the measurement of 2-stroke engines a pair of pick up is available as optional extra. The integrated compensation of torsional vibrations enables an unparalleled accuracy when measuring on 2-stroke engines.

The PREMETS® M is compact, easy to use and very intuitive. Data is being exported via USB and can be analyzed further with the software supplied together with the device. For personnel managing multiple vessels CMT offers a Fleet Management Software.

The non-volatile memory stores up to 18 engine records or up to 125 cylinders. The angle precision of the PREMETS® M is 0.17 deg. The max. cylinder pressure the sensor can be used with is 350 bar. CM Technologies GmbH offers a measurement evaluation service to help you getting the most out of your CMT instrument. Also individual training courses can be arranged either at CMT, at your office or even on board.

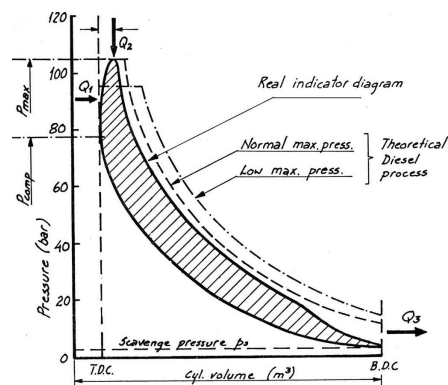

### Your benefits

- Shock prove protector available
- Newly designed using up to date technology
- New analysis software
- Fleet Management software available
- Rugged design for onboard use
- High accuracy
- DNV GL Eco Insight ready
- Economic initial costs
- Exchange Sensor without new calibration of the device



Piezo-SMART-Sensor



PREMETS® M

Specification	
Ignition pressure range	0-350 bar
Sensor	Kistler 6019A 11S
Speed range	20-3000 rpm
Max. number of engines	18
Max. number of cylinders over all engines	125
Max. temperature	400°C
Compensation of torsional vibration	✓
Compensation of pressure vibration	✓
Display	Alphanumeric, size 75 x 25 mm, resolution 20 x 4 char
Accuracy	0.17% degree crank angle

### Ordering Information

DPA-CT-12021

#### PREMETS® M Device

- KISTLER Piezo-SMART-Sensor
- New Premium Analysis Software (PREMETS Viewer)

DPA-CT-12022

#### PREMETS® TDC pick up for 4-stroke engines

DPA-CT-12023

#### PREMETS® pair of Pick ups for 2-stroke engines

DPA-CT-12027

#### Premet pick up connection cable

### 3. PREMET® X

The PREMET® diesel indicators are known to be rugged and reliable. The new generations of PREMET® X now add brand new software, new sensor technology and connectivity to obtain, show, analyse and export the important pressure data of your diesel engine during operations. The PREMET® X gives you the opportunity to fine tune your engine to a higher efficiency resulting in lower costs.

Performance and Efficiency Monitoring



The new PREMET® X

The storage of calibration data inside the sensor makes it possible to easily exchange sensors without calibration of the device. The new software allows an in depth analysis of your engine ensuring you will be in control of the condition of the engine without being an expert user. If your job includes responsibility for multiple vessels the Fleet Management Software will make your life much easier and for worldwide access CMT is offering an online software solution as well. The integrated WiFi connectivity increases the ease of data transfer considerably.

A WiFi network with an internet connection, which can easily be established with a standard mobile phone in the next port will allow an automated upload of the data into the cloud.

The large internal memory of the PREMET® X allows to save as many engine set ups as you like up to 40 cylinders per engine. The integrated compensation of torsional vibrations enables ultra accurate measurements for 2-stroke engines. 4-stroke engines can be measured with an optional TDC sensor with high accuracy. Using an acoustic emission sensor the fuel injection can be monitored with no need to tamper with the high pressure fuel lines during installation. Ignition delay and other critical timings during combustion will become visible. CM Technologies GmbH offers a measurement evaluation service to help you getting the most out of your CMT instrument. Also individual training courses can be arranged either at CMT, your office or even on board.

Compatible with low-, medium- and high-speed engines the PREMET® X is the perfect system to optimise your fuel injections to reduce fuel consumption but also to avoid repairs and damages as part of a condition monitoring regime. The PREMET® X, Made in Germany, is using high-quality materials and is equipped with the newest PiezoSMART sensor from Kistler Switzerland. Latest designed engines run with peak pressures up to 350 bar and high exhaust gas temperatures. The new sensor technology ensures high performance and accurate results for the complete range.

#### Your benefits:

- Revolutionary new sensor technology
- New analysis software
- WiFi connection for easy data transfer
- Rugged design for onboard use
- Highest available accuracy
- DNV GL Eco Insight ready
- Cloud based Fleet Management



#### Ordering Information

DPA-CT-12020

##### PREMET® X Device

- KISTLER Piezo-SMART-Sensor
- New Premium Analysis Software (PREMET Viewer)

DPA-CT-12022

##### PREMET® TDC Pick up for 4-stroke engines

DPA-CT-12023

##### PREMET® pair of pick ups for 2-stroke engines

DPA-CT-12027

##### Premet pick up connection cable

#### Specification

Ignition pressure range	0-350 bar
Sensor	Kistler 6019A 11S
Speed range	20-3000 rpm
Max. number of engines	Unlimited
Max. number of cylinders (per engine)	40
Max. temperature	400°C
Compensation pressure	✓
Compensation of torsional vibration	✓
USB connection	✓
WiFi connection	✓
Display	Colour 160 x 90 mm resolution 800 x 480
Accuracy	0.17% degree crank angle

**Acoustic Emission (AE) waves are commonly defined as transient elastic waves within a material caused by the release of localized stress energy. Hence, an event source is the phenomenon which releases elastic energy into the material, which then propagates as an elastic wave.**

AE events that are commonly studied among material failure processes include the extension of a fatigue crack, or fibre breakage in a composite material.

AE is also related to an irreversible release of energy that can be generated from sources not involving material failure including friction, cavitation and impact. Acoustic emissions can be detected in frequency up to 100 MHz.

Specifications	
Frequency Range:	300-700 kHz (Acoustic Emission)
Operating Temperature:	130°C
Power Supply:	5.0 +/- 0.25 VDC
Output Signal:	0.5-4.0 VDC
Attachment:	Alnico Magnet, 5.2 kg pull force
Diameter:	26 mm
Connector:	Neutrik, NC4MP-BAG

The Acoustic Emission Sensors is a piezoelectric sensor with built-in amplifier and signal conditioning. It is optimised to detects waves in the range of 300 to 700 KHz , which are caused by the injection of the fuel through the nozzle, exhaust gas flow through the valve, impact of the injector needle, closing and opening of the fuel pump spill.

The AE sensor is used to measure the angle at which these events occur and to detect deviations in injection timing, late burning of fuel in the cylinder, leaking injectors.

The optional Acoustic Emission (AE) Sensor can be used for the **PREMET® X**, **PREMET® Single Sensor** and **PREMET® 24/7**. It is not suitable for the use with the **PREMET® M**.

**Your benefits:**

- No penetration of the fuel system
- Eliminates possible fuel leakage
- Applicable for 2-stroke and 4-stroke engines

**Ordering Information**

DPA-CT-12026  
**Acoustic Emission Sensor**

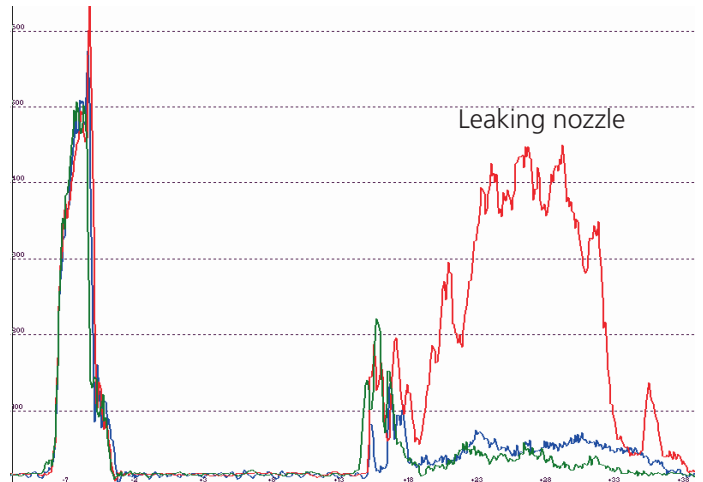
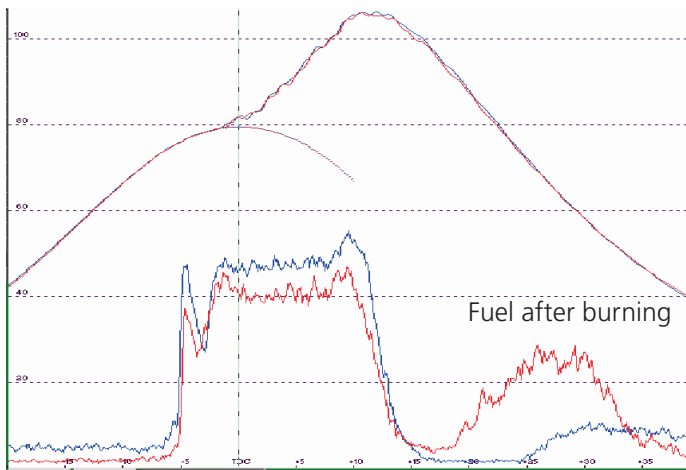

## 4. PREMET® Software

### PREMET® Viewer

The PREMET® Viewer helps to analyse the combustion process more efficiently. With an import of measurement data from a PREMET® X or M you can create TDC graphs, Combustion and Decomposition Curves and p-V Diagrams to help with the condition monitoring of your engines.

The software is included in the delivery of a PREMET from the newest generation. It facilitates the evaluation of the engine condition. A variety of diagrams, bar plots and tables present the measurements incl. manually entered data in a user friendly way.

Data from older generations of PREMETs, DieselsCOPE and Diesel Indicator, DPA devices by DREW Chemicals and all BAEWERT and HLV devices by Kistler or MAN can be evaluated too. Therefore, the transition from an older diesel performance analyser is much easier and you can see trends immediately with the data of your previous devices.

The correct adjustment of the engine helps to reduce the engine's operating costs. Cylinder-to-cylinder load balancing and the correct fuel injection settings will optimise the engine performance and minimize the specific fuel oil consumption. Another main feature of the software is the trend analysis. These trends can help to detect worn parts or incorrect adjustment and plan you repairs as well as avoid unexpected failure.

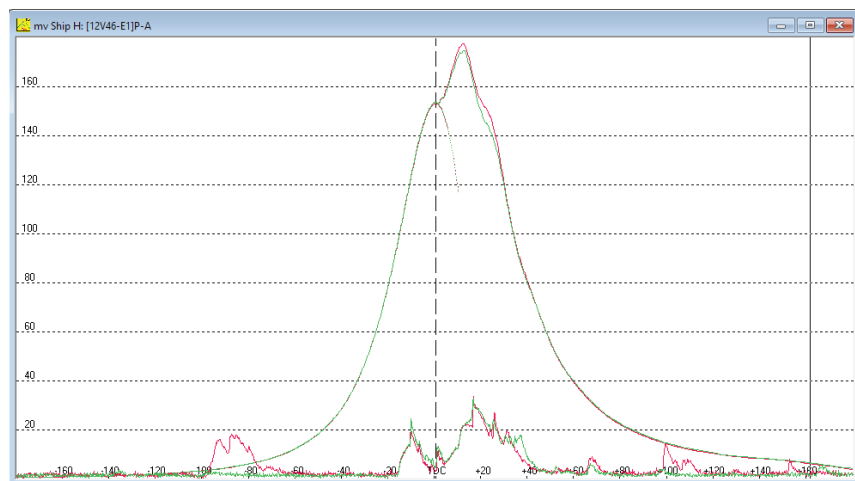

Combustion process

#### Your benefits:

- Easy comparison with previous or sea trial data.
- Upload of Records into the optional PREMET Cloud Solution.
- Allows to read in records from other devices like:
  - PREMET all devices from 2nd and 1st generation
  - Diesel SCOPE and Diesel Indicator previously sold by CMT
  - All DPA devices sold by DREW Chemicals
  - All BAEWERT and HLV devices sold by Kistler or MAN
- Showing the first and second derivate to conclude correct TDC (Top Dead Centre) setting.
- Combustion Decomposition Curve.
- Logarithmic view of p-V Diagram (pressure-volume) to find TDC problems as well as thermal or pressure leakages during combustion process.
- High resolution data processing with the option of filtering to smooth the graph with adjustable low pass filter.
- Can be upgraded to Fleet Management Software including fleet comparison and trending capability.
- Simple adjustable and flexible report creation with all necessary parameters.
- Free of charge with every purchase of a PREMET X or M.

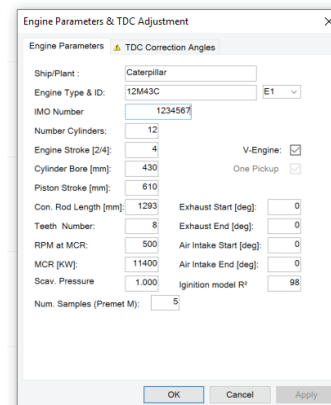

Engine setup

The most used functions of the PREMET Viewer for evaluation are:

- The Pressure-Volume (p-V) diagram can indicate leakage or the incorrect setting of the TDC.
- The TDC Correction is used to maximise the power generated by the engine with lower loss.
- The Combustion Pressure Decomposition Curve is especially for modern engines with a very late ignition point.

All the insights gained can be incorporated into prepared reports for better compilation and distribution so that action can be taken quickly.

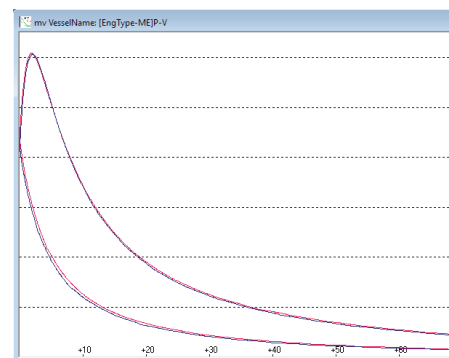

p-v Diagram

#### Ordering Information

DPA-CT-12039

##### PREMET® Viewer

- Included with every purchase of a PREMET

DPS-CT-12133

##### Data Transfer Kit PREMET® SW

DPS-CT-12134

##### Data Transfer Kit HLV-Device

While every PREMETS® device comes including the PREMETS® Viewer, there is an even more beneficial solution. The PREMETS® Cloud allows an analysis from a single ship to complete fleets. Everything is stored in the cloud and can be accessed from all over the world. And the best thing? Its free to use, just register.

Management of the engines on board is nowadays crucial to reduce costs, adhere to modern maintenance requirements and to guarantee 24/7 reliable operation.

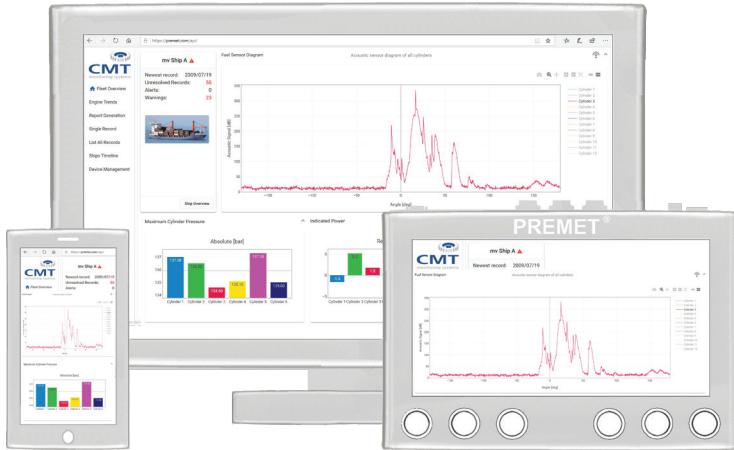

*Availability - everywhere, anytime, instant and for everybody on your team*

An **annual cloud subscription for the ship** is all you need to purchase, but all user accounts are free. The PREMETS® Cloud offers the **most modern DPA** with the **most complete number of parameters**.

For a retrospectively trend analysis, you can also **upload data from other devices** for example, older PREMETS, HLV, DieselsCOPE or Diesel Indicators etc.

**Comparison between sister engines** within the fleet can help a lot and is easily done within the PREMETS® Cloud.

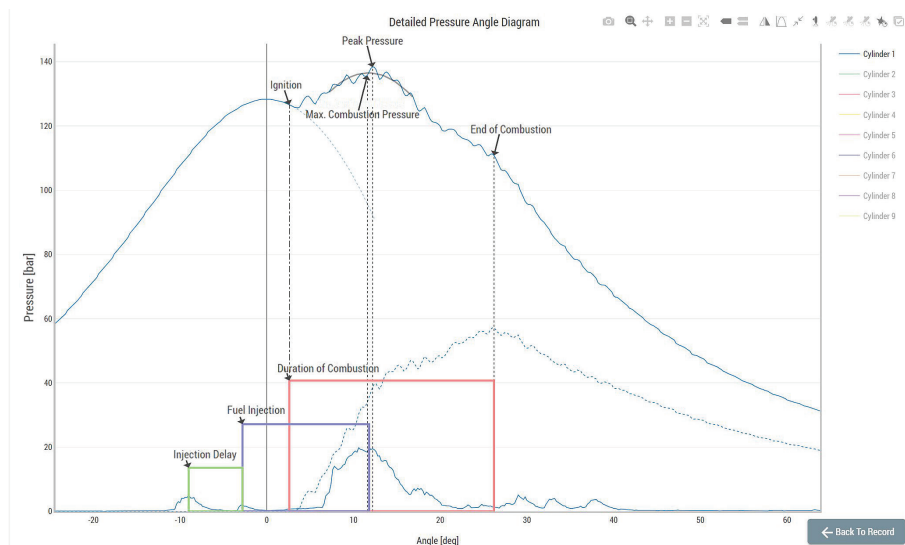

*Extensive - complete analysis with no compromises*



*Cloud based - neat and uncomplicated*

## Your benefits:

- Free to use for all co-workers
- Easy account managing
- Only the ship needs an annual upload license
- Optional analysis service by marine engineers
- Worldwide access with all current browsers
- Most extensive Diesel Performance Analysis on the go
- Only software to show:
  - Maximum combustion pressure
  - Combustion pressure decomposition curve
  - Calculated point of ignition
  - Injection timing parameter

## Alerts

### Compression pressure alert on cylinder 1.

The compression pressure is -5.0 bars away from average. Should be less than 2.0 bars.

### Maximum combustion pressure alert on cylinder 1.

The maximum pressure is 10.7 bars away from the average. Should be less than 3.0 bars.

### Mean indicated pressure alert on cylinder 1.

The mean indicated pressure is 3.1 bars away from average. Should be less than 0.5 bar.

### Maximum combustion pressure alert on cylinder 3.

The maximum pressure is -4.3 bars away from the average. Should be less than 3.0 bars.

### Compression pressure alert on cylinder 4.

The compression pressure is 2.4 bars away from average. Should be less than 2.0 bars.

### Compression pressure alert on cylinder 5.

The Compression pressure is 2.5 bars away from average. Should be less than 2.0 bars.

*Clear - Alert system for quick actions*

Fuel Injection Duration

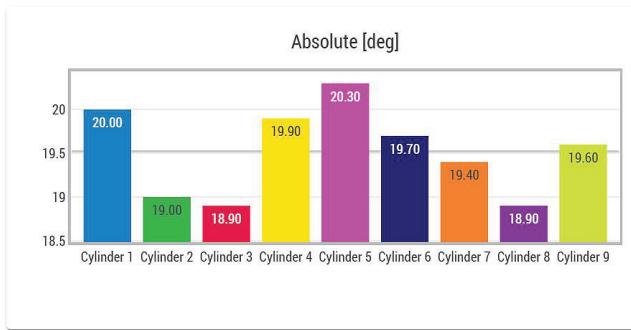

Fuel Combustion Duration

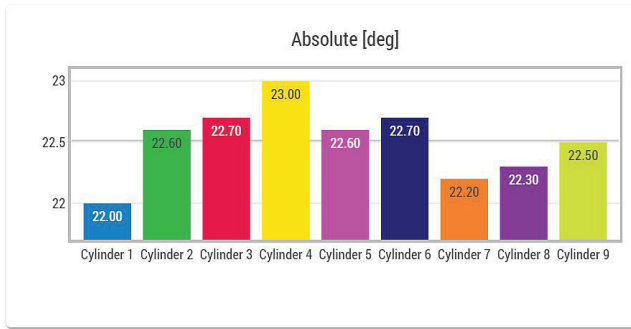

Ignition Delay

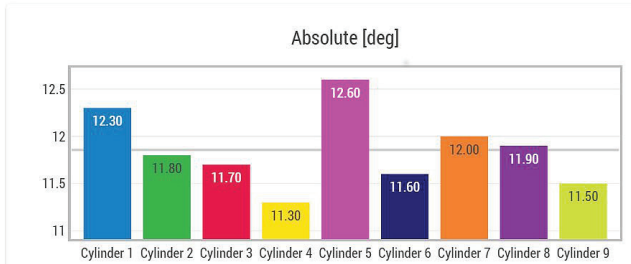

Interpretation - easy comparison of absolute and relative values

The PREMETS® Cloud solution serves as exchange platform and analysing tool for your diesel performance data or your entire fleet. You can manage your fleet, trend performance data and compare data from sister engines, shop or sea trials.

Why not using one of the many other performance clouds available? Because normal fuel performance and ship performance clouds use a limited amount of data while a record of diesel performance data consists of a large array of data which are all necessary to get a conclusive analysis for the diesel engine. If needed calculated performance data can be exported to be used in other clouds.



Assistance by external marine engineers - easy and tailored reports

The big advantage of the PREMETS® Cloud is the instant availability of data. The ship can easily upload data. Either from a registered computer or from a PREMETS®X device.

The uploaded files are just a few kilobytes in size. Data is then at once available for the superintendent or any data analyst who can analyse the data immediately.

All the Data is accessible from any device with internet access from anywhere in the world.

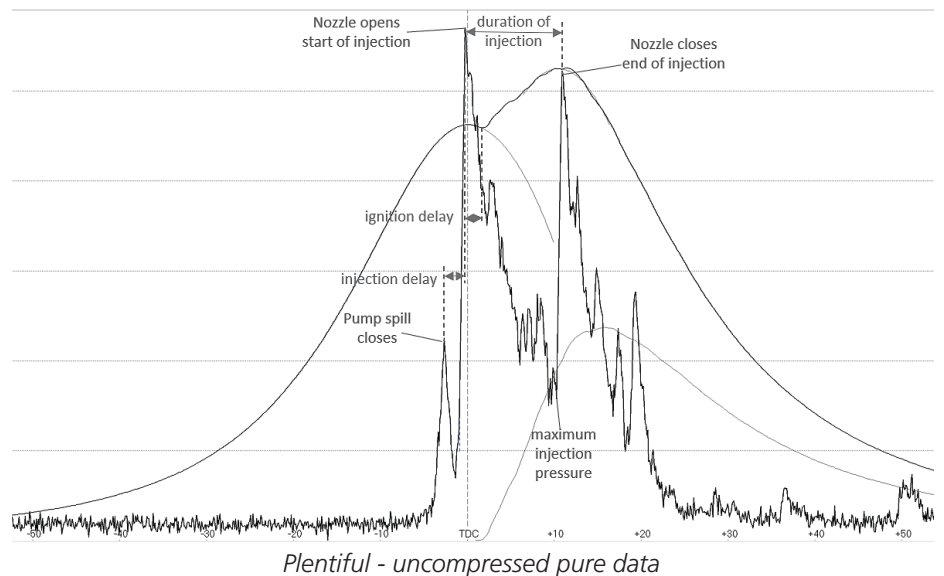

Plentiful - uncompressed pure data

## Complete list of parameters analysed in the PREMETS® Cloud\*:

- Revolutions per Minute (RPM)
- Mean Indicated Pressure (MIP)
- Indicated Power (PI)
- Pressure at Fuel Ignition
- Angle at Fuel Ignition
- Compression Pressure
- Max. Combustion Pressure
- Angle at Max. Combustion Pressure
- Max. absolute Peak Pressure
- Angle at max. absolute Peak Pressure
- Angle where combustion ends
- Expansion Pressure
- $\text{Lambda} = p(\text{mxc}) / p(\text{cmp})$
- Combustion Pressure Rise
- Exhaust Gas Temperature
- Fuel Pump Index
- Ignition Delay =  $a(\text{ign}) - a(\text{opn})$
- Injection Delay =  $a(\text{opn}) - a(\text{pmp})$
- Angle where pump spill closes
- Angle where nozzle opens
- Angle where injection starts
- Fuel Injection Duration (length)

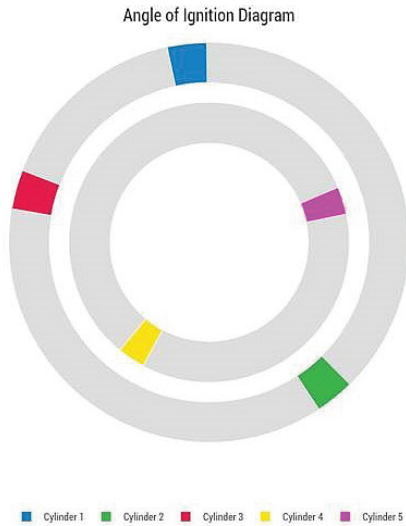

Visual - eye catching arrangement

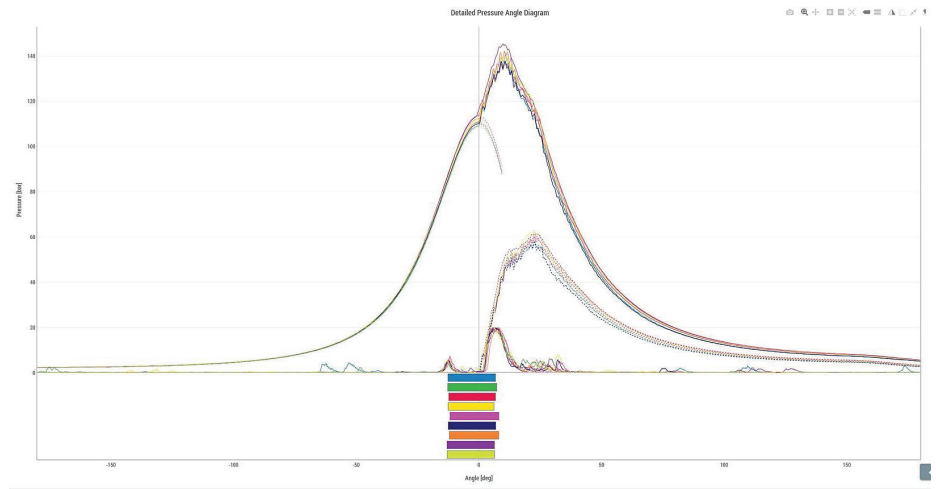

Analysis Summary

**Fuel pump timing to be checked**

Analyst Comments

Compression pressure variation is acceptable.

Ignition timing needs improvement to bring the engine into balance.

Unit 8 does ignite very early. The pump spill closes about 0.5 deg early but ignition starts well over one deg early. This may be due to lower opening pressure of the fuel valve. This is also confirmed due to the latest closing time of fuel valve.

Unit 5 and 7 are about 0.5 deg to late which results in to high load on this two units. Especially on unit 5 this results in

Recommended Actions

Unit 8: Please check opening pressure of fuel valve (possible to low).

Fuel pump timing of unit number 5 and 7 should be brought forward by 0.5 deg.

Please take another measurement after above redommended actions.

Detailed - Complete reports with actions

The PREMETS® Cloud is the only available software on the market with:

- **Maximum combustion pressure**  
Instead of maximum pressure at indicator valve the PREMETS® Cloud calculates the most probable value by FFT analysis for the highest accuracy.
- **Combustion pressure decomposition curve**  
Identify combustion problems like insufficient injected fuel volume as well as the combustion length for each individual cylinder
- **Calculated point of ignition**  
Easy improvement of the accuracy by adapting the coefficient of determination.
- Individual determination for **injection and combustion timing** on each cylinder like:
  - Angle **pump spill closes** including **ignition delay** \*\*
  - Angle **nozzle opening** including **injection delay** \*\*
  - **Point of ignition**
  - Point of **nozzle closing** including **length of injection**\*\*
  - **End of combustion** including **length of combustion**

\* To take advantage of all parameters a PREMETS® from the third generation or newer will be needed.

\*\* (if optional AE sensor is used)

### Ordering Information

DPA-CT-12025

**PREMETS® Cloud Fleet Management Subscription**

DPA-CT-12040

**DPA Evaluation Service**

(per year per engine) subscription required

DPA-CT-12046

**DPA Evaluation Service**

(per year per sister engine)

DPA-CT-12041

**DPA Evaluation Service 3 records**

(10, 25, 50 records per request)

subscription required

## 5. PREMET Online - 24/7

The PREMET® Online 24/7 is the most advanced system for continuous diesel engine performance. It has been developed to be used for one Main Engine Only.

It can monitor up to 16 cylinders and log the data permanently. The Electronic Combustion Analyser is a comprehensive system for continuous engine performance measurement and monitoring which will provide the key knowledge for obtaining optimum and reliable engine performance data. Using the combustion information you will have minimum engine wear, an optimum emission and fuel consumption.



### Technical Data Sensor

Measuring Range:	A24 (0...200 bar), A14 (0...103 bar), A34 (0...300 bar)
Sensitivity:	A24 (50 µA/bar), A14 (100 µA/bar), A34 (33,3 µA/bar)
Overload:	300 bar
Connector (IP67):	M12x1
Linearity at 23°C:	< ± 0,75 %FSO
Mounting Torque:	15 N • m
Zero Point (no pressure):	10 mA
Signal Stroke FSO	10 mA
Operating temp. range, Sensor front:	-50...350 °C
Operating temp. at cable connect.:	-20...200 °C
Operating temp. Charge amplifier:	-10...85°C
Supply Voltage:	16...30 V DC
Weight:	150 g

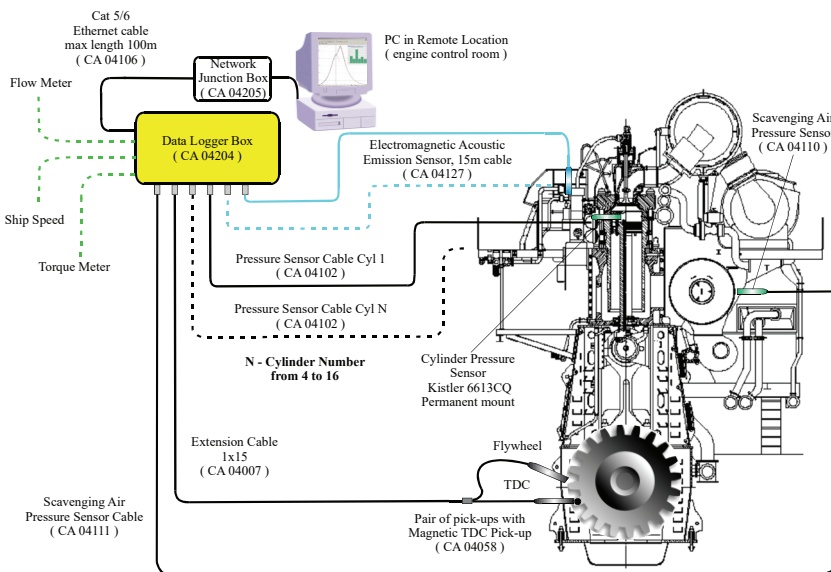

MAIN ENGINE MONITORING SYSTEM



### Your benefits:

- Longer lifetime of components
- Optimized maintenance planning
- Early fault detection
- Increased operational safety
- Lower fuel consumption
- Easy technical reporting

### Your Features:

- Synchronous cylinder pressure measurement of up to 16 cylinders
- 3 x 4-20 mA Inputs
- 4 x Digital Outputs
- 2 x 62 Diagrams Buffer
- p(max) alarm record
- USB data transfer to PC

### Ordering Information

Customized system  
- Please contact our office to discuss details

## 6. Pressure and Temperature Calibration

Pressure Pump



Calibration of measuring devices is very important to guarantee precise results even a long time after manufacturing. Most devices will suffer from degradation of accuracy over a longer period of time. CMT offers an inhouse calibration service or alternatively devices for the calibration of pressure and temperature measuring devices on board. They are available as standalone or in a combined kit.

The Temperature Calibrator is a true calibration with no simulation. It works with a dry heat block and no liquids are required for stable and accurate heat measurements. Therefore the stability of the Temperature Calibrator is as low as 0,1%. The range enables calibration of devices from 30°C - 650°C and is heated for measurements within 14 min.

The Pressure Calibrator also operates with true calibration. The device can be fine adjusted with the valve on the site. With a complete sealed system, the Pressure Calibrator can keep compressions from -0,8 to 60 bar stable.

Different adapters can be used with many different fluids to calibrate a huge variance of devices. The pressure is generated with a handpump, so no external compressor is needed. The size makes it perfect for every calibration on board and the simplicity enables the use by every crewmember.

The PM205 is a microprocessor controlled, accurate and versatile digital pressure measuring and calibration instrument with integrated fast peak-, max.- and min.-function.

The PM205 is supplied with an internal battery with 1000 hours continuous operation in MANO-Mode, guaranteed by the AUTO SWITCHOFF function. This digital pressure gauge finds its specific utilization in marine industry, onboard ships and mobile offshore units and in general manifold industrial fields.

Temperature Calibrator



### Your benefits:

- Onboard recalibration of equipment
- More precision for measurements
- More efficiency with accordingly calibrated equipment.

Calibration Combi Set



### Ordering Information

CBT-CT-00001

#### Temperature Calibrator TC65M

Range: 30 - 650 °C

CBT-CT-00002

#### Pressure Calibrator PM205

Range: (-)0,8 - 60 bar

CBT-CT-00003

#### Calibration Kit for TC/PM

CBT-CT-00005

#### Calibrators Temp./Pres. Combination

Combines all of the above incl. case



## Service and Training

1. Evaluation Service .....	89
2. Installation and Commission Service.....	90
3. Calibration Service .....	92
4. Oil Testing Seminar .....	94
5. Monitoring with Vibration Analysis Seminar.....	95
6. Diesel Performance Seminar.....	96
7. Cylinder Drain Oil Management Seminar .....	97
8. Marine Water Tests Seminar.....	98

## Overview Training and Services



**Condition Monitoring is the basis for condition based maintenance. CMT does not stop at providing condition monitoring technologies but does go a step beyond to provide also services to get a CM system running and also to keep the equipment in a good condition.**

CMT offers a broad range of modernization and optimization solutions that keep the vessel competitive and prolong its profitable life cycle. Retrofit options are provided to enhance productivity, safety, energy efficiency and environmental impact. By choosing CMT you gain a dedicated partner with capability for consulting, implementing and overseeing the complete modernization project.

Services available include turnkey installation, commissioning, remote data analysis and reporting, as well as suggested reliability improvements based on the monitored results.



# 1. Evaluation Service

Make the most out of your existing measuring tools or get our help to get started. CMT experts will help you to make sense of data gathered by Diesel Performance Analysers, Vibration Monitoring Equipment or your Fuel oil and Lube Oil Condition Monitoring devices. CMT will accompany you from the purchase of the device, implementation up to the interpretation of the data gathered.



Service and Training

SDA LAB REPORT		CMT						
IMO number Vessel name Component	IMO XXXXX MS OELCHECK 2 stroke marine diesel engine	Customer number: 2021100 Manufacturer: XXXX Engine model: XXXX Engine speed: 75 rpm All lubricants in operation: Yes Ambient temperature: 45°C Longitude: 47° 28' 00" W Latitude: 27° 50' 20" S Fuel sulphur content: 0.1 mg/kg Fuel viscosity content: 87 mg/kg System id: XXXXXX-XXXXXX-XXX Date sample taken: 01/07/2014 Contact: OELCHECK	Total operating hrs: 24027 h Engine model: XXXX Engine speed: 75 rpm Scavenging air temperature: 100°C Inboard: 42% Lab date: 27/02/2014 Fuel A:S content: 23 mg/kg Date tested: 08/07/2014 Phone number: 0048 8024 8047 210					
Diagnosis for the current laboratory values Residual BH is adequate to avoid corrosion but low on cylinders 3 and 7. A fuel rate increase on cylinders 3 and 7 is recommended to ensure that corrosion is controlled. Residual BH is not high enough on some cylinders to verify increased a fuel rate reduction. Soot, Chromium and Copper are in the normal range. PO Index is higher than expected for operators 1, 3, 4 and 6 but not critical. Vanadium and nickel contents are high but not a cause for concern. Sulfur content is all well within the expected range. Excess oil content in cylinder 2 could be high in an engine context. This would indicate wear of the stuffing box seals. Viscosity at 40°C is relatively high but does not require attention. Recommendation that you send us the next sample for third determination. Please highlight all sample information in future, this allows a more detailed assessment to be made. Dip. Wang. 010 0000 0000 Action								
ANALYSIS RESULTS								
LAB NUMBER	1702021	1702022	1702023	1702024	1702025	1702026	1702027	1702028
CYLINDER NUMBER	1	2	3	4	5	6	7	8
SAMPLE ID	Average	1st	2nd	3rd	4th	5th	6th	7th
PREVIOUS SAMPLE RATING								
08/07/2014								
24/08/2014								
24/08/2014								
Fuel rate	g/kWh	0.9	0.8	0.8	0.8	0.8	0.8	1.0
WEAR								
BH	µg/kg	62	50	108	122	90	25	71
Chromium	µg/kg	9	7	10	9	3	2	2
Copper	µg/kg	3	2	4	5	2	2	1
PO Index		20	27	25	28	24	24	25
CONTAMINATION								
Boron	µg/kg	103	108	138	110	90	21	102
Aluminum	µg/kg	23	24	29	29	23	12	16
Barium	µg/kg	120	105	182	183	127	80	103
Nickel	µg/kg	178	158	228	242	180	132	148
Vanadium	µg/kg	591	527	841	851	597	431	448
Sulfur	µg/kg	26070	20761	34148	31954	28274	20450	20552
Water	%	2.11	2.62	2.4	2.42	2.06	2.09	1.77
Sulfur content	%	0.1	0.2	<0.1	0.1	<0.1	0.2	<0.1
Excess oil content > 20%		8.7	11.2	3.2	3.8	6.5	6.5	6.8
OIL CONDITION								
Viscosity at 40°C	mm <sup>2</sup> /s	488.14	431.89	368.16	397.91	406.10	341.98	351.97
Sh	mg/100g	27.62	34.50	31.75	37.81	24.89	23.87	26.20
ADDITIONS								
Cadmium	µg/kg	20270	23280	23868	22876	24000	20608	20974
Magnesium	µg/kg	114	127	159	132	114	80	88
Zinc	µg/kg	187	190	242	189	188	168	195
Phosphorus	µg/kg	29	19	62	27	41	17	14

In today's busy and hectic work environment it is more and more difficult to get the most out of the tools which are available due to time constraints or limited available personnel. Also measuring tools which have been identified as useful and valuable are not being purchased because of the already full work schedule of the personnel responsible for the implementation.

In other cases the knowledge of the intended user is being considered as inadequate to use the tool effectively or there are even fears a misinterpretation of achieved results will interfere with normal operations and cause a disruption rather than be a help.



However most technical personnel agree that if monitoring tools are being used correctly and the evaluation of the results is being done properly it will help to bring down maintenance costs, prevent down times and improve the bottom line.

CMT has recognized this and is offering an evaluation service for results obtained for Diesel Performance, Vibration and Oil condition. It does not start and end with the interpretation of the results but we will offer help for the implementation of the devices, the individual set up of the instruments and training. Either let us help to get you started or let us provide our service the whole way. We are prepared to offer individual services as per your need- just get in touch and we will find a solution.



### Deliverables:

- Help & guidance to set up your monitoring regime
- CMT Experts interpret and evaluate measuring data
- Reports which indicate problems and help to find the reason

### Benefits:

- No need for an in house specialist
- Free your personnel so that they can focus on their duties
- Get an expert opinion
- Make sure purchased tools are being used efficiently
- Prevent damages and keep your equipment running

## 2. Installation and Commission Service



**Our long experience with installation and commissioning on board seagoing vessels ensures cost-effective retrofit or new building installations including final commissioning that are carried out with a minimum on interruption to your business. As a turn-key supplier we can handle every phase of a project from design and engineering to installation, commissioning and training.**

**CMT has a qualified team of installation and commissioning engineers with a wealth of experience in on site requirements. Installations and commissioning can be offered with all equipment purchased from CMT.**

The expanding world fleet operates in an uncertain environment, with ever tougher competition and increasing price pressures, which puts the spotlight on safe and cost-effective ship operation. This requires a partner able to maintain the new, more advanced vessels as well as keeping the ageing fleet operating safely, more efficiently, and up to date to stricter standards. Off-hire must be mitigated or prevented.

**Highly skilled and qualified support for the start-up of your condition monitoring system.**

We have teams of experienced and qualified technicians to provide you with support for the turn-key installation and commissioning of condition monitoring systems purchased from CMT.

When we provide installation and commissioning services – whether for a control systems or a complete package – our technicians work alongside the project managers and engineers to ensure smooth and efficient installation to the highest standard.

In the early stages of your system life we want to ensure you get everything you need to meet project time lines and site needs.

### **Our services include:**

- Installation
- Pre-commissioning and Commissioning
- Site Acceptance Testing
- Personnel Introductory Training
- Support at system start up
- Operating and Maintenance Documents
- Spares installation / repair
- Fault Finding

A tailored commissioning visit proposal can also be produced (if not offered as part of the original contract) based on a set of specific terms and conditions. CMT service engineers regularly travel the World, keeping our valued overseas clients equipment in full working order. In most cases seven days notice is needed to arrange a commissioning visit.

Even if the condition monitoring equipment was not installed by CMT, our team will be happy to quote for a commissioning visit, safety inspection, or full material handling service contract. Just make a request and we'll take care of your condition monitoring equipment service needs.





**CMT has developed commissioning routines that ensure the work is carried out safely and effectively, and that your crew has the knowledge and confidence to operate the vessel to a high standard.**

All CMT Automation products are designed with easy installation and commissioning in mind and will have passed comprehensive testing at the factory before they reach the shipyard or the vessel. The commissioning process follows established routines that ensure the work is carried out effectively, safely, and to a high standard which will provide the foundation for reliable life cycle performance.

The on-site commissioning activities include visual inspection, electrical and mechanical tests on equipment, and functional and integration tests on systems. The commissioning phase ends with sea trials which include the final tuning of the equipment, handover of updated documentation, and performing the official tests for the equipment and vessel.

#### **Your benefits:**

- Worldwide Service with flying crew.
- System installations and commissioning of systems are undertaken with minimum interruption to your facility
- Flexibility for challenging vessel schedules, weekend or evening work
- Method statements and risk assessments carried out
- Special training programmes undertaken - see Training section for more information

We are always happy to discuss specific requirements and our business is based on tailoring services to your exact needs - please contact us for any further information you require.



### 3. Calibration Service

**CMT offers a calibration for a huge number of devices. Calibration is very important to guarantee precise results even a long time after manufacturing.**

We recommend calibration for all of our devices every two years.

The next calibration date from our devices will be noted on a label on the device as well as on the calibration certificate.

We also calibrate devices similar to our own.

Calibration of test equipment is essential to maintaining confidence and reliance on the readings obtained from them to get reliable condition monitoring results. Whether motivated by regulatory requirements or by the need for assurance of measurements critical to a manufacturing process, regular calibration of your instrument is critical to having a reference based on known standards. Besides the reference measuring instruments and the calibration services that CMT offers, we also offer a line of calibration standards that you can use to validate your devices in use.

Beside a calibration service for all devices from our own portfolio we cover many other calibration services for any third party product.

Calibrations are performed in an

expeditious fashion, with turnaround times of less than one week in most cases. Calibration price is at a Flat Rate cost and covers all labour and equipment to perform one calibration required to meet our specifications. The calibration is provided by CMT as an ISO 9001:2015 certified company to ensure highest quality and traceability. If your instrument requires repairing, the repair service will include standard calibration. Custom calibration or accredited calibration can also be included for an additional fee.

#### Traceable Calibration

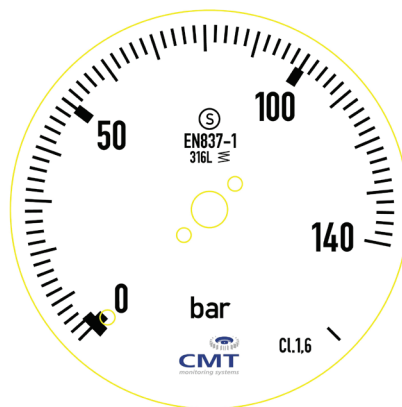

Calibration means that the test results from a measuring device of unknown accuracy, are compared with a device whose accuracy is known. This device is universally accepted as a "reference".

Calibrations are traceable to the

International System of Units (SI) through National Metrological Institutes, and natural physical constants.

Calibration records any deviation from this standard and corrects it when necessary. Each instrument has a specific calibration procedure which indicates exactly how and what must be checked. Regular and traceable calibration combines the forces of accuracy and certainty and provides you with the key aspect of ISO 9001:2015 certification.

#### Your benefits:

- Ensure highly accurate measurements
- Provide certification and mandatory documentation for instrument calibration standards
- Enjoy peace of mind with CMT-certified calibration expertise and components

#### Ordering Information

The calibration process varies for each device group. Please contact our sales team for specific information or quotes.

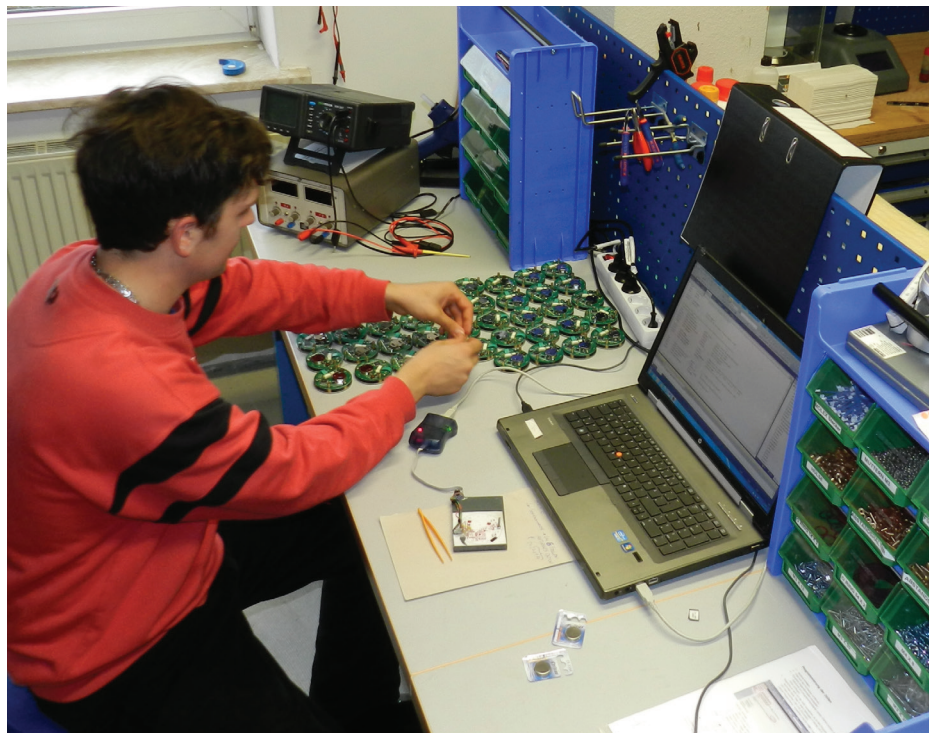

## Overview Training

**Doing business in an environment which relies heavily on the help of machinery to get the job done put high demands on the education of the employees seeing to the operation and maintenance.**

Vessels, machines, plants and industrial sites are environments where a good education of the work force makes sure to protect your investment and is key for a flawless operation.

Either make sure that your employees are properly trained in the use of a tool you have invested in or raise their level of knowledge about a specific topic both will make sure that your equipment life will be optimal, lowest maintenance cost levels are achieved and reliability is at a maximum.

We at CM Technologies GmbH understand that and are offering several training courses for fixed topics. However we also understand that the background of the participants can be very different and that each customer looking for a training may have unique requirements therefore we are able to offer customized trainings suited for the needs of the individual customers.

Trainings are being held at our facility or a nearby conference centre. Upon request trainings can be held on site at the customer facilities may they be a marine vessel, factory or office.

Small groups ensure an efficient training, so we usually limit the number of participants to a maximum of 8-12 persons. If you have a larger group you want to book a training for, contact us to discuss possibilities.

Standard course duration is usually one working day, customized trainings may deviate.



### Deliverables:

- Training on basic to advanced monitoring topics, professionally delivered by knowledgeable CMT trainer and, as appropriate, by external speaker.
- Certificate to participants.
- Detailed seminar documentation for later reference.
- Small groups for most effective training.

### Your benefits:

- Increase competency and value of personnel.
- Increase equipment life, reliability and availability through effective and efficient monitoring practices.
- Opportunity for engineering / maintenance personnel to learn and exchange useful information.
- Updated on most current industry knowledge and experience as well as on latest legislation.



## 4. Oil Testing Seminar

**Oil is used in various crucial different applications and has different important tasks to fulfil. Lubrication oil is used to avoid friction between moving parts and therefore to avoid wear or damages.**

Hydraulic oil is used to transmit forces and the hydraulic systems are used in nearly all industries. Oils are also expected to cool or to avoid contaminations which would cause harm to the engine. Oils in modern equipment are complex and expensive liquids. It is therefore important to understand and maintain the oil. Oil can tell us long stories about the performance of the equipment.



Source: Oel Check GmbH

### Lube oil is the life blood of your engine!

#### Training Topics:

- Introduction
- Basic tribology
- Friction, wear and lubrication
- Life-cycle of the oil
- Sampling and sample handling
- Trend analysis in laboratories
- Interpretation of results
- On-site testing - blessing or burden
- Frequencies of testing

#### Target Group:

- Sales personnel of mineral oil companies
- Technical application engineers
- Technical crews from seagoing vessels
- Technical superintendents
- OEM and component producers
- Service providers in the area of lubrication, lubricants and tribology



#### Specification:

- Participants: max. 12
- Location: Training Centre Elmshorn or on-site
- Duration: 1 day 9:00 – 17:00

#### Deliverables:

- Training held by industry professionals
- Modified training content on request
- Hot lunch
- Non-alcoholic beverages & snacks during training
- Training documents (printed and on a USB Flash drive)
- Certificate of participation

## 5. Monitoring with Vibration Analysis Seminar

Vibration diagnostics tools are here to help us to predict the machine failures. When predictive maintenance is applied and the machines are checked regularly, machine faults can be discovered at an early stage and appropriate action can be taken. By doing so you can avoid unexpected machine shutdowns and you can prevent replacement of parts which are still in good condition.

To use the tools effectively and to help with the implementation CMT offers a Vibration seminar. Depending on the level of the knowledge of the participants the seminar can be amended accordingly. Also in some cases an on site training may be beneficial so make sure to let us know your requirements.



**Increase the lifetime of your equipment!**

### Training Topics :

- Introduction into Vibration Analysis Monitoring
- Measuring parameters or perform vibration diagnosis
- Vibration monitoring devices
- Machinery vibration diagnostic
- Bearing vibration diagnostic
- Air leaks detection
- Working with DDS Database
- Hands-on training with VA portable instruments
- Using routes for effective data collection
- FFT Frequency analysis and data export
- Typical failure modes
- Field experience

### Target Group:

- Technical application engineers
- Technical crews from seagoing vessels
- Technical superintendents
- Service and maintenance personnel
- Service providers in the area of vibration monitoring

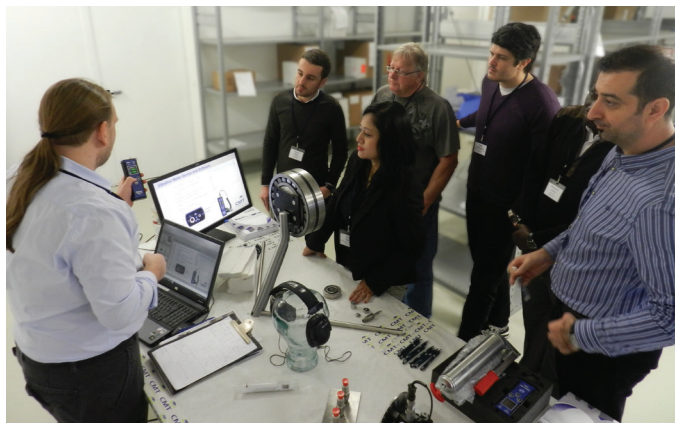

### Specification:

- Participants: max. 12
- Location: Training Centre Elmshorn or on-site
- Duration: 1 day 9:00 – 17:00

### Deliverables:

- Training held by industry professionals
- Modified training content on request
- Hot lunch
- Non-alcoholic beverages & snacks during training
- Training documents (printed and on a USB Flash drive)
- Certificate of participation



## 6. Diesel Performance Seminar

**The challenge of upholding a maintenance regime on board ships is to protect the vessel against costly downtime and to operate it cost effectively. Engine maintenance can be planned, thus saving in parts and labour by changing engine parts based on need, not based on timing intervals.**

Slow or late combustion is one of the most common problems in diesel engine operation. Balancing the cylinder load extends engine life, increases efficiency, and reduces emissions to assist with environmental compliance. Proper ignition timing reduces the exhaust gas temperature and rate of excess carbon build-up. Tuning the engine may reduce specific fuel oil consumption resulting in significant savings which are paramount to a ship owner's bottom line.



**Improve the efficiency of your engine!**

### Training Topics:

- Introduction into Diesel Engine Performance Analysis
- Defining different pressures and angles, calculate indicated power
- Identification of problems by using the pressure / angle and pressure / volume diagram
- Cylinder load balance
- What influences the ignition time?
- Results of late ignition and how can it be identified?
- Slow or late combustion. Results and how can it be identified?
- Interpreting results and taking actions.
- Field experience

### Target Group:

- Technical application engineers
- Technical crews from seagoing vessels
- Technical superintendents
- OEM and component producers
- Service providers in the engine maintenance



### Specification:

- Participants: max. 12
- Location: Training Centre Elmshorn or on-site
- Duration: 1 day 9:00 – 17:00

### Deliverables:

- Training held by industry professionals
- Modified training content on request
- Hot lunch
- Non-alcoholic beverages & snacks during training
- Training documents (printed and on a USB Flash drive)
- Certificate of participation



## 7. Cylinder Drain Oil Management Seminar

**Cylinder oil in a main engine has two main tasks. It should lubricate the engine to have an acceptable low wear level and it has to neutralize the sulphuric acid to avoid unexpected acid corrosion in the liner.**

By analysing scrapedown oil collected from the scavenge space shipboard personnel are able to monitor the condition of the engine's cylinders and detect changes as they occur. This task helps to protect the engine, optimise the feed rate, monitor for mechanical & corrosive wear and reduce maintenance and operating costs.



Protect the liner of your engine!

### Training Topics:

- How is a cylinder lubricated / piston running conditions / different lubrication systems
- Cylinder wear, types of wear and how is it detected and measured / monitored
- Low / high sulphur fuel – what does sulphur in respect of the lubrication regime? Legislations
- The sulphur / base balance – optimise the feed rate
- Cylinder Drain Oil Analysis – onshore / on board
- Sampling the drain oil, how and when
- Interpreting results and taking actions
- Field experience

### Target Group:

- Sales personnel of mineral oil companies
- Technical application engineers
- Technical crews from seagoing vessels
- Technical superintendents
- Service providers in the area of lubricants and tribology



### Specification:

- Participants: max. 12
- Location: Training Centre Elmshorn or on-site
- Duration: 1 day 9:00 – 17:00

### Deliverables:

- Training held by industry professionals
- Modified training content on request
- Hot lunch
- Non-alcoholic beverages & snacks during training
- Training documents (printed and on a USB Flash drive)
- Certificate of participation

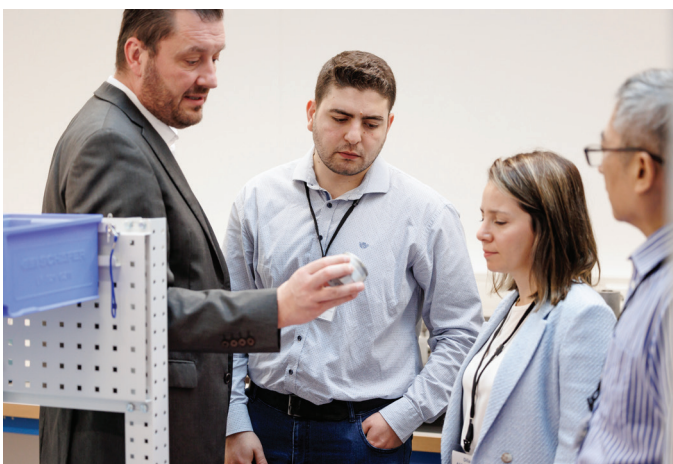

## 8. Marine Water Tests Seminar

Water is an important topic onboard a vessel which due to different regulations concerning it also a quite complicated one. As key topics we have identified Potable Water, Sewage Water and Ballast Water for which we each offer training courses.

If you would like to combine topics let us know and we will work on a customized seminar that is tailored to your needs. Our experienced seminar speaker will tackle topics that need to be addressed as well as answer questions which originate from the daily work experience of the participants.



Safe potable water secures good health!

### Training Topics:

- Introduction into potable water
- Risks for fresh water supply and making on board
- Hazardous contaminations (microbes / chemical elements)
- Different methods of disinfection
- Legionella and other bacteria
- Legislation framework
- Risk Management and Water Safety Plan
- Ship owners / masters duties
- Water testing: What, When, Where, Why?
- How to use on-board test kits

### Target Group:

- Technical application engineers
- Technical crews from seagoing vessels
- Technical superintendents
- Service and maintenance personnel
- OEM and component producers
- Service providers in the area of water monitoring



### Specification:

- Participants: max. 12
- Location: Training Centre Elmshorn or on-site
- Duration: 1 day 9:00 – 17:00

### Deliverables:

- Training held by industry professionals
- Modified training content on request
- Hot lunch
- Non-alcoholic beverages & snacks during training
- Training documents (printed and on a USB Flash drive)
- Certificate of participation





CM Technologies GmbH  
Schmiedestrasse 15  
25348 Glueckstadt, Germany  
Tel: +49 (4124) 50443 0  
Email: [info@CMTechnologies.de](mailto:info@CMTechnologies.de)  
Web: [www.CMTechnologies.de](http://www.CMTechnologies.de)

